

## *SOLENOID CONTROLLED, PILOT OPERATED AIR VALVES*

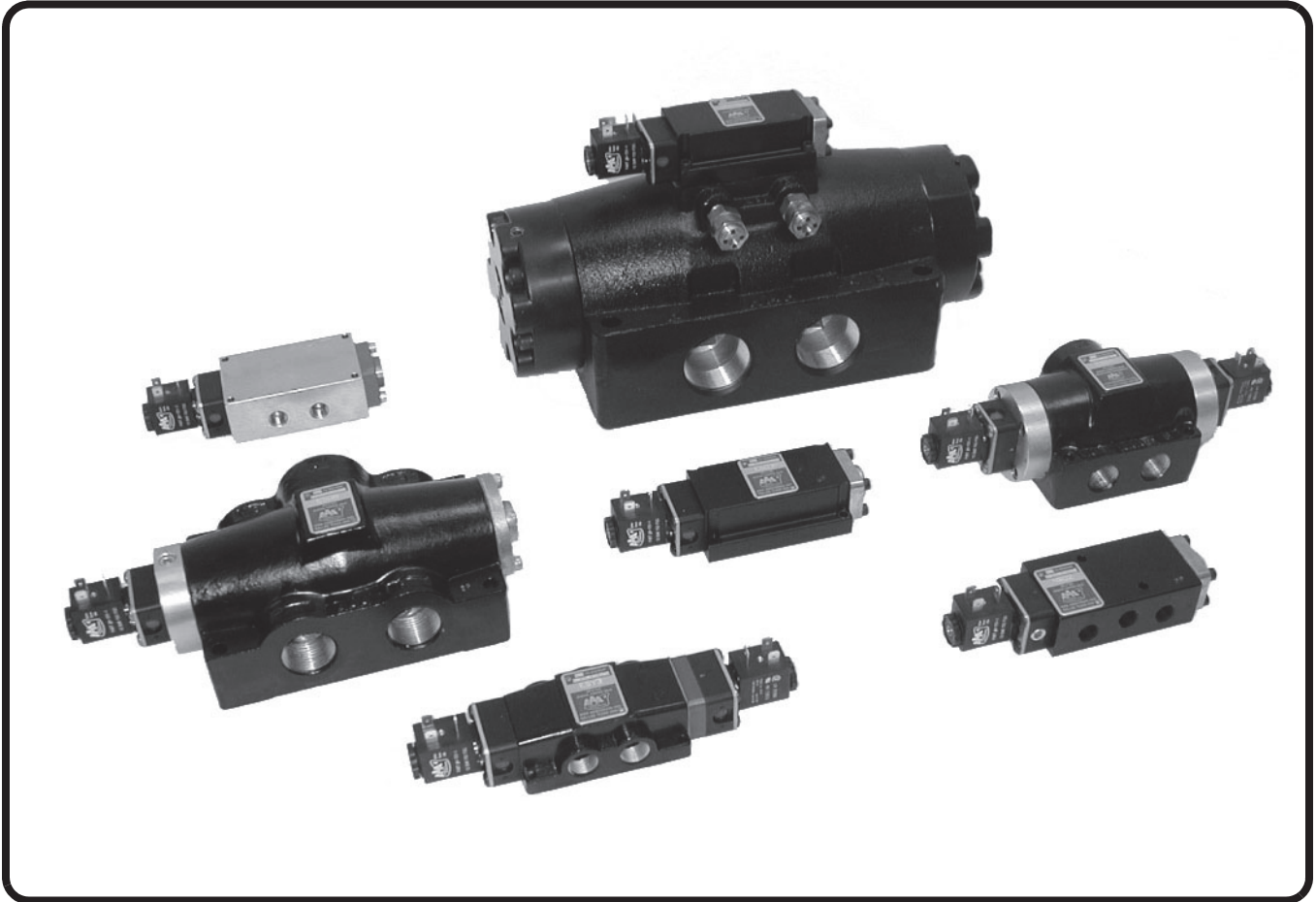

4-WAY: VACUUM TO 250 PSI



### **PART NUMBER STRUCTURE:**

- Part 1:** The basic part number of an AAA valve is fairly simple to understand. The first part is both an operator style and valve operation. This position describes not only how the valve shifts positions but also what shifts the spool.
- Part 2:** The second portion is the valve port size and body style. This portion describes whether the valve is a threaded side ported body or a bottom bored subplate body.
- Part 3:** The third part of the part number structure is the spool configuration. Normally only needed on three position valves, the spool configuration defines the flow at center position. You can have a spool other than the standard "Closed Center" on two position valves; however, the transitional flow is normally not needed for most applications.
- Part 4:** The fourth part is the solenoid operator style. AAA valves can have several different coils and operator types. Leaving this position blank will use the common standard coil.
- Part 5:** The fifth position of the part number structure is used to specify valve options. You can specify different solenoid vents, locking overrides or assembled for "External Pilot" operation by choosing options available for the valve configuration you need.
- Part 6:** The final position allows you to specify different O-rings used in the main valve body. You choose the O-ring most suited for your application. This specification applies to the body O-rings and not the solenoid or any additional seal materials. On most applications that require special seals, the valve must be configured for "External Pilot".

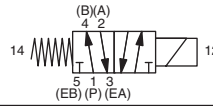
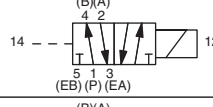
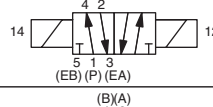
**ESS3PGMZ-5-120/60** (Voltage: e.g. 120/60, 24 vdc)

1 Operator Style		
Code	Description	Symbol
ESO	Single solenoid, 2-position, spring return. Spool returns to position "C" when solenoid is de-energized.	
ESR	Single solenoid, 2-position, pilot returned spool. Spool returns to position "C" from auxiliary control valve furnished by the user.	
ESS	Double solenoid, 2-position, friction position. Spool shifts and remains shifted when one solenoid or the other is momentarily or continuously energized.	
ESY	Double solenoid, 3-position, spring centered. Spool returns to center, position "B", when both coils are de-energized.	

2 Body Style	
<b>Side Ported</b>	
2	1/4" NPTF
3	3/8" NPTF
4	1/2" NPTF
6	3/4" NPTF
8	1" NPTF
12	1-1/2" NPTF
<b>Subplate Mounted</b>	
3P	3/8" flow
4P	1/2" flow
8P	1" flow
16P	1-1/2" flow

**3 Spool Configuration** (Normally on 3-position valves, 2-position valves use a closed center spool)

blank = Closed cross over, all ports are blocked in the center position.  
 D = Regenerative center, ports 2 & 4 are connectect to port 1, ports 3 & 5 are blocked.  
 G = Float center, port 2 is connected to port 3, port 4 is connected to port 5, port 1 is blocked.

**4 Solenoid Operator Form**

blank = Standard "DIN" style solenoid coil with 11mm/Industrial Form B pin pattern.  
 A = Intrinsically safe solenoid operator and coil with non-indicator, cord grip style DIN cap.  
 H = 30 mm DIN for high temperature applications.  
 J = Mold-Over coil, with 1/2"-14 NPT conduit connection.  
 M = Flying lead solenoid coil, with 18" leads.  
 X = Explosion proof solenoid coil.

**5 Valve Options**

blank = No options selected.  
 C = Side solenoid exhaust (can not be combined with option "L").  
 I = Non-threaded spool indicator pin (available only on models ESO2, ESO3, ESO3P).  
 K = Threaded spool indicator pin (available only on models ESO2, ESO3, ESO3P).  
 L = Sintered bronze dust excluder on solenoid exhaust (can not be combined with option "C").  
 O = Locking manual solenoid override.  
 OS = Manual main spool override (available only on models ESO2, ESO3, ESO3P).  
 Q = 2-postion spool detent (available only on models ESR & ESS with limited body styles).  
 U = Factory installed muffler/flow controls in ports 3 and 5 (body styles 2, 3 & 4 only).  
 Z = Factory assembled for "External Pilot" operation.

**6 Valve O-Ring Option** (Only applies to valve body O-Rings)

blank = Viton for body styles 2, 3 & 3P, Buna-N for body styles 4, 6, 8, 12, 4P, 8P & 16P.  
 -1 = Neoprene for freon (-40°F to 225°F).  
 -2 = Silicon (-80°F to 400°F).  
 -3 = Viton for most aromatic gases (-20°F to 400°F, 600°F for short time).  
 -4 = Butyl Rubber (-60°F to 200°F).  
 -5 = Teflon (-250°F to 450°F).  
 -7 = Urethane, 70 Durometer (-65°F to 200°F).  
 -9 = Buna-N (-40°F to 250°F).

## ***GENERAL INFORMATION***

Standard solenoid models are assembled for "Internal Pilot" operation; that is, the valves derive shifting pressure for the spool from the valve inlet port. The required pressure to shift the spool is dependent upon the operator style. If the valve must operate at other pressures or vacuum, then the solenoid operator must use an "External Pilot" source at a pressure between 25 PSI to 150 PSI. Valves that require external pilot pressure can be ordered from the factory with the "Z" Option or be converted in the field for "External Pilot" operation.

When using an "External Pilot" source, the maximum pressure of any port is 250 PSI and the maximum vacuum of any port is 28" Hg. A combination of pressure and vacuum on multiple ports is permissible as long as the differential pressure does not exceed 250 PSI.

### **OPERATOR STYLE CODE:**

**ESO:** Single solenoid, 2-position, spring return. Spool returns to original position when solenoid is de-energized. This operator style will operate reliably on line pressures from 150 PSI down to 50 PSI. If the line pressure is 150 PSI to 250 PSI or less than 50 PSI to 28" Hg, then the solenoid operator must be configured to use an "External Pilot" source.

**ESR:** Single solenoid, 2-position, pilot returned spool. Spool returns to position "C" from auxiliary control valve furnished by the user. This operator style will operate reliably on line pressures from 150 PSI down to 25 PSI. Return shift pressure should be 25 PSI or greater. If the line pressure is 150 PSI to 250 PSI or less than 25 PSI to 28" Hg, then the solenoid operator must be configured to use an "External Pilot" source.

**ESS:** Double solenoid, 2-position, no springs. Spool shifts and remains shifted when one solenoid or the other is momentarily or continuously energized. Standard models are assembled for "Internal Pilot" operation. This operator style will operate reliably on line pressures from 150 PSI down to 25 PSI. If the line pressure is 150 PSI to 250 PSI or less than 25 PSI to 28" Hg, then the solenoid operator must be configured to use an "External Pilot" source.

**ESY:** Double solenoid, 3-position, spring centered. Spool is centered when both solenoids are de-energized. Standard models are assembled for "Internal Pilot" operation. This operator style will operate reliably on line pressures from 150 PSI down to 50 PSI. If the line pressure is 150 PSI to 250 PSI or less than 50 PSI to 28" Hg, then the solenoid operator must be configured to use an "External Pilot" source.

### **BODY STYLE:**

**SIDE PORTED:** Side ported valves can be installed inline. These valves have standard female "National Pipe Threads" to connect directly to installed air lines. The standard pipe sizes are 1/4", 3/8", 1/2", 3/4", 1" and 1-1/2" NPTF.

**SUBPLATE MOUNTED:** Subplated valves require a mounting base. This mounting base is pre-plumbed to existing control lines. Due to the nature of the plumbing lines fixed to a mounting base, replacing subplate mounted valves is rapid and quick. All port connections, excluding "External Pilot" or "Pilot Return" ports, if used, are made through O-ring sealed holes in the base of the valve through a subplate. O-ring seals and mounting screws are furnished with each subplate valve. Because the connections to a base mount can be of any size and configuration, subplate mounted valves are assigned a designation derived from a basic valve body size. A 3P size subplate valve will have the same flow characteristics as a 3/8" NPTF side ported valve body. Consult factory on the possibility of routing external pilot or pilot return sources through the subplate on body styles 4P and 8P.

### **SPOOL CONFIGURATION (FOR 3-POSITION VALVES):**

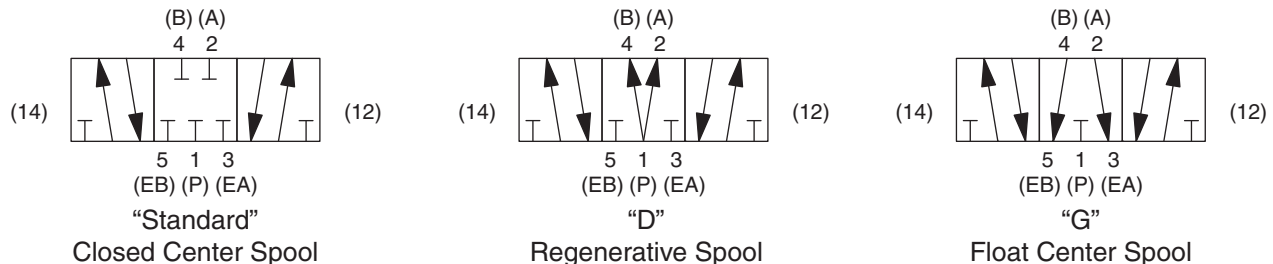

**STANDARD:** Most valves are supplied with a "Closed Center" spool. In the center position, all ports are blocked. If a valve is only a 2-position valve, the actual function of the center position is not critical. So most 2-position valves are "Closed Center". Some designs do require softer transitions, so we offer alternate spool configurations on 2-position valves.

**REGENERATIVE:** Spool Option "D". In the center position or during transition, ports 2 and 4 are connected to port 1. We call this a "Regenerative" spool since both cylinder ports 2 and 4 are supplied with pressure and flow from port 1.

**FLOAT CENTER:** Spool Option "G". In the center position or during transition, port 2 is connected to port 3 and port 4 is connected to port 5. We call this a "Float Center" spool since both standard cylinder ports 2 and 4 are vented to an exhaust port and no pressure or flow from port 1 is supplied.

# SOLENOID OPERATOR FORMS:

## STANDARD SOLENOID OPERATOR INFORMATION

The standard coils are a DIN 43650 style with a 11mm/Industrial Form B connector pin pattern. DIN caps are ordered as a separate line item. *Voltage must be specified when ordering.*

**Voltages:** This chart shows most common voltages. Consult the AAA factory for other voltages which may be available.

Coil Voltage and Frequency	Pick-Up	Holding	Resistance
24 volts, 60 Hz	7.1 VA	5.8 VA	31.6 ohms
48 volts, 60 Hz	7.7 VA	6.2 VA	121 ohms
120 volts, 60 Hz	7.8 VA	6.3 VA	840 ohms
240 volts, 60 Hz	7.8 VA	6.3 VA	3400 ohms
12 volts D-C		4.6 Watts	31.6 ohms
24 volts D-C		4.8 Watts	121 ohms
60 volts D-C		4.3 Watts	840 ohms

**DIN Caps (11mm style):** Various styles of DIN caps are available as lose items, see below for more information.

**Environmental Ratings:** (With mounted plug-in connector per IEC 529) IP 65 (NEMA 4 without structural rating).

**Certifications:** This operator carries both a UL and CSA approval rating. The rating only applies to the operator and not the entire valve.

**Voltage Tolerance:** ±10%.

**Resistance Tolerance:** ±8% @ 20@ 20°C.

**Operating Temperatures:** -4°F to 120°F.

**Moulding Material:** Duroplast/thermoset resin (Duro).

**Operating Pressures:** 29" Hg vacuum - 250 PSIG. Standard models are assembled for "Internal Pilot" operation. They will operate reliably on line pressures from 150 PSIG down to 25 PSIG minimum for no spring models and down to 50 PSIG on spring return and spring centered models. Above 150 PSIG, below minimum pressure and for vacuum service, the valve must be configured for "External Pilot" (Between 50 PSIG and 150 PSIG).

**Solenoid Seal Material:** The internal gasket material is Viton, for both the plunger seat and override seal. Consult the factory for seals made of Buna-N or other materials.

**Mounting Gasket:** The gasket that mounts the solenoid assembly to the valve is Buna-N.

**Tapped Exhaust:** Solenoid stems are tapped 10-32/5mm-0.8 for piped exhaust.

**Manual Override:** Solenoid structures are equipped with a non-locking manual override on the side of the solenoid structure. To activate manual override, the inset plunger must be depressed. Spool will shift while the plunger is depressed but will return to original position on spring models ESO and ESY when plunger is returned to normal (Sufficient shifting pressure and pilot source is assumed). Spool will remain shifted on springless models ESS and ESR. For locking overrides, see valve option "O" on page 20.

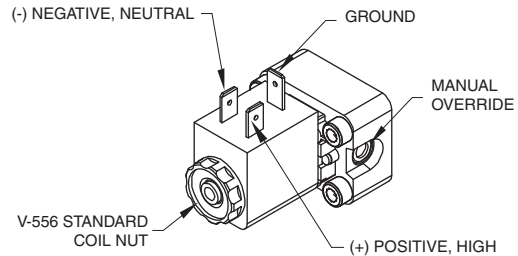

Solenoid Terminal Definitions

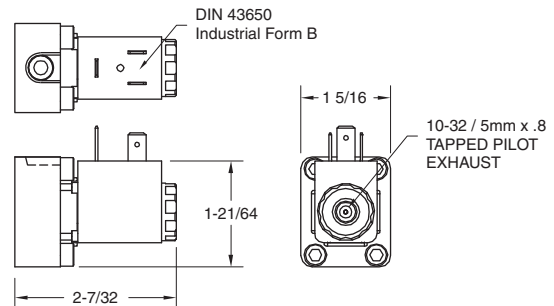

Standard Solenoid Operator

## OPTIONAL DIN CAPS FOR STANDARD COILS

DIN caps are not supplied with standard solenoid valves. These caps must be ordered separately. Below are the DIN caps commonly used.

There are several styles of DIN caps. *When ordering LED Indicator types, you must specify voltage of solenoid coil (E.g. DCL-120/60).* All caps listed in table are for 11mm/Industrial Form B coils, consult factory for additional forms available. LED Indicator type caps are equipped with varistor surge protection (Diode surge protection available upon request).

**Environmental Rating:** IP 65

Model No.	Style	LED	Model No.	Style	LED
DCC	1/2" Conduit	no	DCCL	1/2" Conduit	yes
DCG	3/8" Grip	no	DCGL	3/8" Grip	yes
DC3M*	3 Meter Cord	no	DC3ML*	3 Meter Cord	yes

\*Consult factory for other lengths of cord.

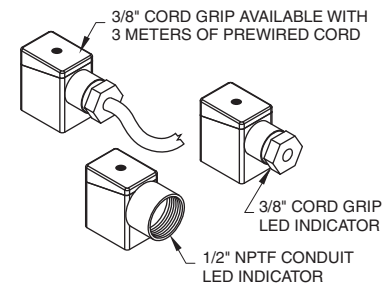

DIN Cap Styles

## STANDARD 1/4" THROUGH 2" SOLENOID: ESO, ESR, ESS, ESY

### OPERATOR STYLE A: INTRINSICALLY SAFE SOLENOID COIL

When related to solenoid valves, intrinsic safety means that the coil's current draw and resulting temperature is held to such a low level (When used with an approved safety barrier) that the valve no longer has the capability of igniting a mixture of flammable or combustible material, either during normal operation or under fault conditions.

Typically, they are used in situations where fire and explosive hazards exist due to the presence of flammable gases, vapors or liquids, combustible dusts or easily ignitable fibers.

These 24 VDC coils are approved according to EN 50 020 resp. DIN VDE 0170/0171 part 5. This coil is an ISO 4400 DIN style pin pattern. A non-indicator, cord grip style DIN cap provided.

To order solenoid valves with this coil type, use the suffix "A" (E.g. ESO2A). Intrinsically safe coils can not be placed on our standard solenoid assembly. This coil must be used with the proper operator and intrinsically safe barrier to function correctly. DIN caps are provided.

**Electrical Characteristics:** 21.6 - 28 VDC.

**Max. Safe Valve:** 28 VDC, 115 mA, 1.6W.

**Electrical Characteristics:** 37mA, 275 ohms  $\pm$  8%.

**Environmental Ratings:** (With mounted plug-in connector per IEC 529) IP 65 (NEMA 4 without structural rating).

**Certifications:** This operator carries both FM and CSA approval rating. The rating only applies to the operator and not the entire valve.

**Operating Temperatures:** -4°F to 120°F.

**Moulding Material:** Duroplast/thermoset resin (Duro).

**Operating Pressures:** 29" Hg vacuum - 250 PSIG. Standard models are assembled for "Internal Pilot" operation. They will operate reliably on line pressures from 150 PSIG down to 25 PSIG minimum for no spring models and down to 50 PSIG on spring return and spring centered models. Above 150 PSIG, below minimum pressure and for vacuum service, the valve must be configured for "External Pilot" (Between 50 PSIG and 150 PSIG).

**Solenoid Seal Material:** The internal gasket material is Viton, for both the plunger seat and override seal. Consult the factory for seals made of Buna-N or other materials.

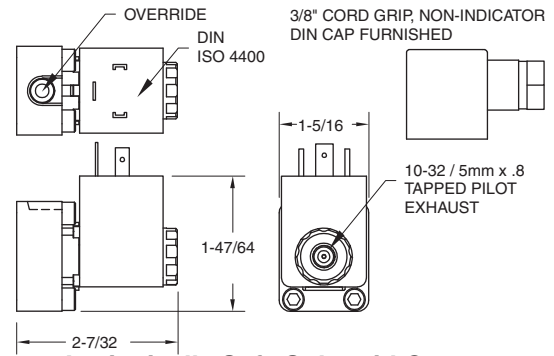

**Intrinsic Safe Solenoid Operator**

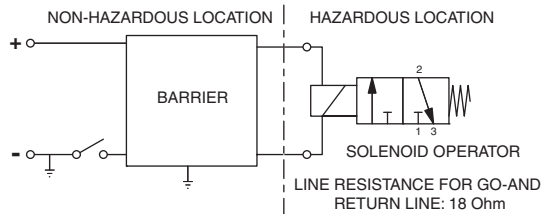

**Mounting Gasket:** The gasket that mounts the solenoid assembly to the valve is Buna-N.

**Tapped Exhaust:** Solenoid stems are tapped 10-32/5mm-0.8 for piped exhaust.

**Manual Override:** Solenoid structures are equipped with a non-locking manual override on the side of the solenoid structure. To activate manual override, the inset plunger must be depressed. Spool will shift while the plunger is depressed but will return to original position on spring models ESO and ESY when plunger is returned to normal (Sufficient shifting pressure and pilot source is assumed). Spool will remain shifted on springless models ESS and ESR. For locking overrides, see valve option "O" on page 20.

### COMPATIBLE BARRIER MANUFACTURERS

(Contact information may change)

Pepperl & Fuchs® Inc. • Telephone (330) 425-3555 • FAX: (330) 425-4607

Pepperl+Fuchs, Inc., 1600 Enterprise Parkway, Twinsburg, Ohio 44087

E-mail: sales@us.pepperl-fuchs.com • www.am.pepperl-fuchs.com

Models: KFD2-SLS-EX2 and KFD2-SD-EX1.36

Measurement Technology LTD. • Telephone (905) 840-7850 • FAX: (905) 840-7852

MTL Canada Safety Instrumentation

20 Regan Road, Unit 17, Brampton, Ontario L7A 1C3

E-mail: cinfo@mtlnh.com • www.mtl-group.com

Model: MTL3021

STAHL, INC. • Telephone: (603) 870-9500 • FAX: (603) 870-9290

Corporate Headquarters and Manufacturing

45 Northwestern Drive, Salem, New Hampshire 03079-4809

E-Mail: sales@rstahl.com • www.rstahl.com

Model: 9004/01-280-050-00

**OPERATOR STYLE H: 30MM COIL, HIGH TEMPERATURE COIL**

30MM coils have same characteristics and performance as our standard coils, but have a ISO 4400 connector pin pattern. DIN caps are ordered as a separate line item. This coil is capable of higher temperatures than the other coils. To order solenoid valves with this coil type, use the suffix "H" (E.g. ESO2H 24 vdc). *Voltage must be specified when ordering.*

**Voltages:** This chart shows most common voltages. Consult the AAA factory for other voltages which may be available.

Coil Voltage and Frequency	Inrush Current	Holding Current	Resistance
120 volts, 60 Hz	56 mA	34 mA	800 ohms
240 volts, 60 Hz	27 mA	17 mA	3205 ohms
12 volts D-C		218 mA	55 ohms
24 volts D-C		111 mA	216 ohms

**DIN Caps (ISO 4400 style):** Various styles of DIN caps are available as lose items, see below for more information.

**Environmental Ratings:** (With mounted plug-in connector) IP 65 (NEMA 4 without structural rating).

**Certifications:** This operator carries both UL and CSA approval rating. The rating only applies to the operator and not the entire valve.

**Voltage Tolerance:** ±10%.

**Resistance Tolerance:** ±8% @ 20°C.

**Operating Temperatures:** -4°F to 190°F.

**Moulding Material:** Duroplast/thermoset resin (Duro).

**Operating Pressures:** 29" Hg vacuum - 250 PSIG. Standard models are assembled for "Internal Pilot" operation. They will operate reliably on line pressures from 150 PSIG down to 25 PSIG minimum for no spring models and down to 50 PSIG on spring return and spring centered models. Above 150 PSIG, below minimum pressure and for vacuum service, the valve must be configured for "External Pilot" (Between 50 PSIG and 150 PSIG).

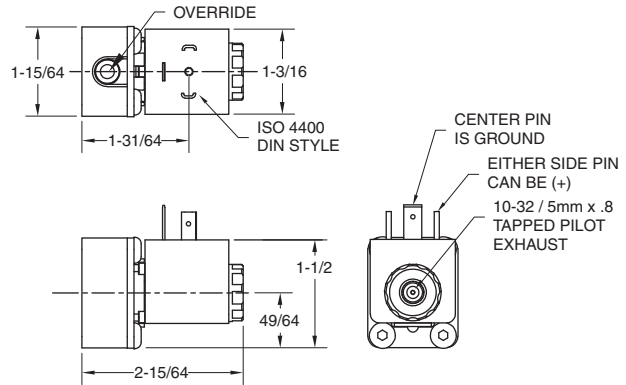

**High Temperature Solenoid Operator**

**Solenoid Seal Material:** The internal gasket material is Viton, for both the plunger seat and override seal. Consult the factory for seals made of Buna-N or other materials.

**Mounting Gasket:** The gasket that mounts the solenoid assembly to the valve is Buna-N.

**Tapped Exhaust:** Solenoid stems are tapped 10-32/5mm-0.8 for piped exhaust.

**Manual Override:** Solenoid structures are equipped with a non-locking manual override on the side of the solenoid structure. To activate manual override, the inset plunger must be depressed. Spool will shift while the plunger is depressed but will return to original position on spring models ESO and ESY when plunger is returned to normal (Sufficient shifting pressure and pilot source is assumed). Spool will remain shifted on springless models ESS and ESR. For locking overrides, see valve option "O" on page 20.

**OPTIONAL DIN CAPS FOR 30MM COILS**

DIN caps are not supplied with standard solenoid valves. These caps must be ordered separately. Below are the DIN caps commonly used.

There are several styles of DIN caps. When ordering LED Indicator types, you must specify voltage of solenoid coil (E.g. EDCL-120/60). All caps listed in table are for "ISO 4400", consult factory for additional forms available. LED Indicator type caps are equipped with varistor surge protection (Diode surge protection available upon request).

**Environmental Rating:** IP 65

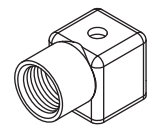

**EDC Cap**

Model No.	Style	LED	Model No.	Style	LED
EDC	1/2" Conduit	no	EDCL	1/2" Conduit	yes

**STANDARD 1/4" THROUGH 2"  
SOLENOID: ESO, ESR, ESS, ESY**

**OPERATOR STYLE J: MOLD-OVER COIL**

“Mold-Over” coils have same characteristics and performance as our standard coils, but have a molded 1/2"-14 NPT connection with 18" leads that are wired through the 1/2"-14 NPT connection. To order solenoid valves with this coil type, use the suffix “J” (E.g. ESO2J 24 vdc). *Voltage must be specified when ordering.*

**Voltages:** This chart shows most common voltages. Consult the AAA factory for other voltages which may be available.

Coil Voltage and Frequency	Pick-Up	Holding	Resistance
24 volts, 60 Hz	7.1 VA	5.8 VA	31.6 ohms
48 volts, 60 Hz	7.7 VA	6.2 VA	121 ohms
120 volts, 60 Hz	7.8 VA	6.3 VA	840 ohms
240 volts, 60 Hz	7.8 VA	6.3 VA	3400 ohms
12 volts D-C		4.6 Watts	31.6 ohms
24 volts D-C		4.8 Watts	121 ohms
60 volts D-C		4.3 Watts	840 ohms

**Environmental Ratings:** (With proper 1/2" NPT connection) IP 65 (NEMA 4 without structural rating).

**Voltage Tolerance:** ±10%.

**Resistance Tolerance:** ±8% @ 20°C.

**Operating Temperatures:** -4°F to 120°F.

**Moulding Material:** Duroplast/thermoset resin (Duro).

**Operating Pressures:** 29" Hg vacuum - 250 PSIG. Standard models are assembled for “Internal Pilot” operation. They will operate reliably on line pressures from 150 PSIG down to 25 PSIG minimum for no spring models and down to 50 PSIG on spring return and spring centered models. Above 150 PSIG, below minimum pressure and for vacuum service, the valve must be configured for “External Pilot” (Between 50 PSIG and 150 PSIG).

**Solenoid Seal Material:** The internal gasket material is Viton, for both the plunger seat and override seal. Consult the factory for seals made of Buna-N or other materials.

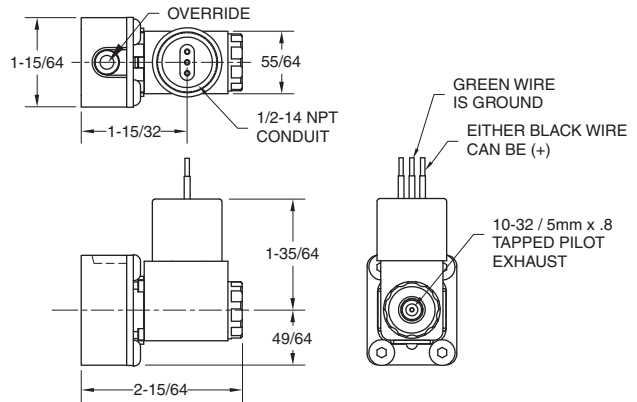

**1/2" Conduit Solenoid Operator**

**Mounting Gasket:** The gasket that mounts the solenoid assembly to the valve is Buna-N.

**Tapped Exhaust:** Solenoid stems are tapped 10-32/5mm-0.8 for piped exhaust.

**Manual Override:** Solenoid structures are equipped with a non-locking manual override on the side of the solenoid structure. To activate manual override, the inset plunger must be depressed. Spool will shift while the plunger is depressed but will return to original position on spring models ESO and ESY when plunger is returned to normal (Sufficient shifting pressure and pilot source is assumed). Spool will remain shifted on springless models ESS and ESR. For locking overrides, see valve option “O” on page 20.

**OPERATOR STYE M: FLYING LEAD SOLENOID COIL**

“Flying Lead” coils have same characteristics and performance as our standard coils, but have 18" lead wires molded with the coil. To order solenoid valves with this coil type, use the suffix “M” (E.g. ESO2M 24 vdc). *Voltage must be specified when ordering.*

**Voltages:** This chart shows most common voltages. Consult the AAA factory for other voltages which may be available.

<b>Coil Voltage and Frequency</b>	<b>Pick-Up</b>	<b>Holding</b>	<b>Resistance</b>
24 volts, 60 Hz	7.1 VA	5.8 VA	31.6 ohms
48 volts, 60 Hz	7.7 VA	6.2 VA	121 ohms
120 volts, 60 Hz	7.8 VA	6.3 VA	840 ohms
240 volts, 60 Hz	7.8 VA	6.3 VA	3400 ohms
12 volts D-C		4.6 Watts	31.6 ohms
24 volts D-C		4.8 Watts	121 ohms
60 volts D-C		4.3 Watts	840 ohms

**Environmental Ratings:** IP 65 (NEMA 4 without structural rating).

**Certifications:** This operator carries both UL and CSA approval rating. The rating only applies to the operator and not the entire valve.

**Voltage Tolerance:** ±10%.

**Resistance Tolerance:** ±8% @ 20°C.

**Operating Temperatures:** -4°F to 120°F.

**Moulding Material:** Duroplast/thermoset resin (Duro).

**Operating Pressures:** 29" Hg vacuum - 250 PSIG. Standard models are assembled for “Internal Pilot” operation. They will operate reliably on line pressures from 150 PSIG down to 25 PSIG minimum for no spring models and down to 50 PSIG on spring return and spring centered models. Above 150 PSIG, below minimum pressure and for vacuum service, the valve must be configured for “External Pilot” (Between 50 PSIG and 150 PSIG).

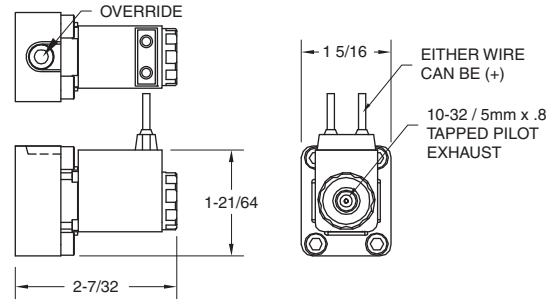

**Flying Lead Solenoid Operator**

**Solenoid Seal Material:** The internal gasket material is Viton, for both the plunger seat and override seal. Consult the factory for seals made of Buna-N or other materials.

**Mounting Gasket:** The gasket that mounts the solenoid assembly to the valve is Buna-N.

**Tapped Exhaust:** Solenoid stems are tapped 10-32/5mm-0.8 for piped exhaust.

**Manual Override:** Solenoid structures are equipped with a non-locking manual override on the side of the solenoid structure. To activate manual override, the inset plunger must be depressed. Spool will shift while the plunger is depressed but will return to original position on spring models ESO and ESY when plunger is returned to normal (Sufficient shifting pressure and pilot source is assumed). Spool will remain shifted on springless models ESS and ESR models. For locking overrides, see valve option “O” on page 20.

**STANDARD 1/4" THROUGH 2"  
SOLENOID: ESO, ESR, ESS, ESY**

**OPERATOR STYLE X: EXPLOSION PROOF SOLENOID COIL**

All "Explosion Proof" solenoid operators carry the FM and CSA label for Class I, Group C and D (Gasoline vapors, etc.), Class II, Groups E, F and G (Coal, coke and grain dusts). The connection is 1/2"-14 NPT conduit with 24" leads. **Note:** The FM and CSA label on an explosion proof solenoid operator covers only the electrical operator and does not cover the complete valve. To order solenoid valves with "Explosion Proof" operators, add suffix "X" to the basic part number (E.g. ESO2X 120/60). *Voltage must be specified when ordering.*

**Voltages:** This chart shows most common voltages. Consult the AAA factory for other voltages which may be available.

Coil Voltage and Frequency	Pick-Up	Holding	Resistance
120 volts, 60 Hz	11.5 VA	6.5 VA	530 ohms
12 volts D-C		4.5 Watts	31.6 ohms
24 volts D-C		4.5 Watts	121 ohms

**Environmental Ratings:** (With proper 1/2" NPT connection) IP 65 (NEMA 4 without structural rating).

**Certifications:** This operator carries both FM and CSA approval rating. The rating only applies to the operator and not the entire valve.

**Voltage Tolerance:** ±10%.

**Resistance Tolerance:** ±8% @ 20°C.

**Operating Temperatures:** -4°F to 120°F.

**Moulding Material:** Duroplast/thermoset resin (Duro).

**Operating Pressures:** 29" Hg vacuum - 250 PSIG. Standard models are assembled for "Internal Pilot" operation. They will operate reliably on line pressures from 150 PSIG down to 25 PSIG minimum for no spring models and down to 50 PSIG on spring return and spring centered models. Above 150 PSIG, below minimum pressure and for vacuum service, the valve must be configured for "External Pilot" (Between 50 PSIG and 150 PSIG).

**Solenoid Seal Material:** The internal gasket material is Viton, for both the plunger seat and override seal. Consult the factory for seals made of Buna-N or other materials.

**Mounting Gasket:** The gasket that mounts the solenoid assembly to the valve is Buna-N.

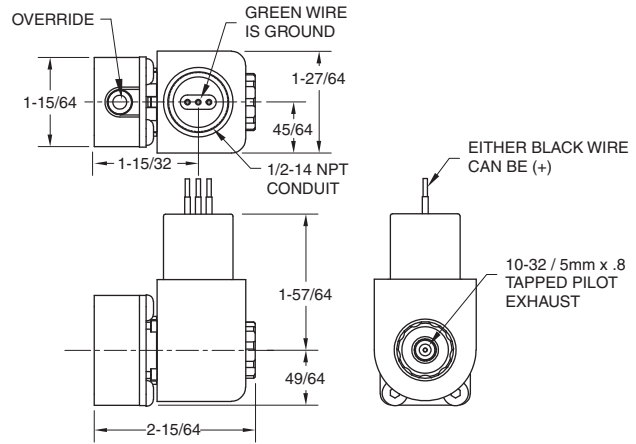

**Explosion Proof Solenoid Operator**

**Tapped Exhaust:** Solenoid stems are tapped 10-32/5mm-0.8 for piped exhaust.

**Manual Override:** Solenoid structures are equipped with a non-locking manual override on the side of the solenoid structure. To activate manual override, the inset plunger must be depressed. Spool will shift while the plunger is depressed but will return to original position on spring models ESO and ESY when plunger is returned to normal (Sufficient shifting pressure and pilot source is assumed). Spool will remain shifted on springless models ESS and ESR. For locking overrides, see valve option "O" on page 20.

**Unique Mounting Concern:** On body styles 2 and 3 a 1/8" spacer or washers are required to mount the valve. **The explosion proof coil hangs below valve mounting surface by 3/32".**

## VALVE OPTIONS:

### STANDARD: ALL SOLENOID FORMS PROVIDE

**Tapped Exhaust:** Solenoid stems are tapped 10-32/5mm-0.8 for piped exhaust. If the valve is ordered with Option “L” or “C”, the 10-32/5mm-0.8 exhaust will be covered by the nut and unusable.

**Manual Override:** Solenoid structures are equipped with a non-locking manual override on the side of the solenoid structure. To activate manual override, the inset plunger must be depressed. Spool will shift while the plunger is depressed but will return to original position on spring models ESO and ESY when plunger is returned to normal (Sufficient shifting pressure and pilot source is assumed). Spool will remain shifted on springless models ESS and ESR. For locking overrides, see valve option “O” on page 20.

**Field Modification:** Able to convert between internal or external solenoid pilot source in the field.

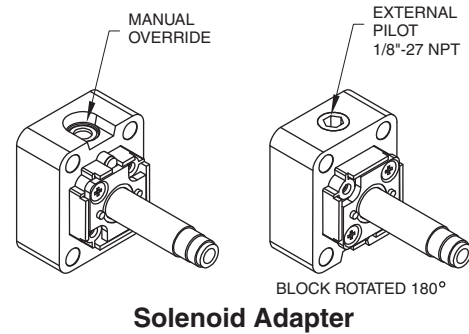

### OPTION I: NON-THREADED SPOOL INDICATOR PIN

Available only on single solenoid, spring return models with body styles of 2, 3 and 3P (ESO2, ESO3, ESO3P). This option allows a pin to protrude through the endcap to indicate the location of the internal spool. This is helpful for actuating a sensor to indicate the shift position of the valve. The pin will extend when the solenoid is energized. The travel of the pin is 18/32". The pin sticks out 3/8" from the face of the endcap when retracted.

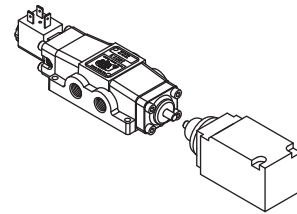

### OPTION K: THREADED SPOOL INDICATOR PIN

Same as Option “I”, the non-threaded spool indicator pin, but the end of the indicator pin is 1/4"-20x3/4" threaded end.

### OPTION L: SINTERED BRONZE DUST EXCLUDER NUT

This option allows the exhaust from the solenoid assembly to be filtered through a sintered bronze element. This causes a reduction in noise and filtering of exhaust. With this option, the 10-32/5mm-0.8 tapped exhaust is inaccessible



### OPTION C: SIDE EXHAUST NUT

This option allows the exhaust from the solenoid assembly to be diffused. This causes a reduction in noise and diffusing of exhaust. With this option the 10-32/5mm-0.8 tapped exhaust is inaccessible.



### OPTION Q: 2-POSITION SPOOL DETENT

Available only on models ESR and ESS with body styles of 2, 3 and 3P. This option allows the spool to remain in position when shifting pressure is removed. This option is most often used in mobile applications where the vibrations may shift the spool when there is no holding pressure available. Overall length of the valve will increase by 1".

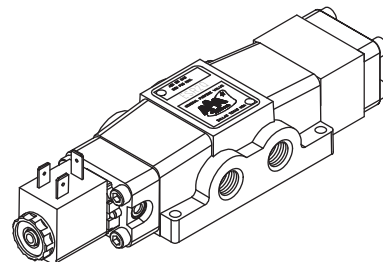

**OPTION O: LOCKING MANUAL SOLENOID OVERRIDE**

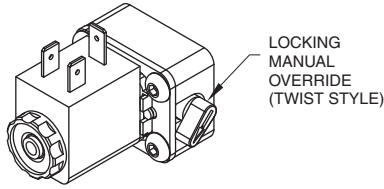

**Locking Manual Solenoid Override**

Solenoid structures with locking overrides are available on original factory orders. To activate manual override, the override knob must be twisted clockwise to the locked position. Spool will shift while the knob is in the override position, but will return to original position on spring models ESO and ESY when knob is returned to normal (Sufficient shifting pressure and pilot source is assumed). Spool will remain shifted on springless models ESS and ESR. Converting to locking override from non-locking override in the field is not possible without replacing the entire solenoid assembly.

**OPTION OS: MANUAL MAIN SPOOL OVERRIDE**

Available only on single solenoid, spring return models with body styles of 2, 3 and 3P (ESO2, ESO3, ESO3P). The override knob is attached to the end of the main spool, allowing the knob to actuate the internal spool. The knob will have to be continuously held to overcome spring return. Minimum operating pressure of 70 PSI is required for reliable valve operation.

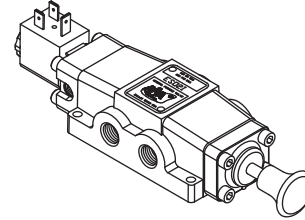

**OPTION U: EXHAUST FLOW CONTROLS**

Available only on body styles 2, 3 and 4. A Model MFC flow control, listed on page 146, is screwed into each exhaust port, giving meter-out speed control of an associated air cylinder or air motor in both directions of travel. MFC flow controls not only give adjustable speed control but have a built-in muffler to reduce exhaust noise.

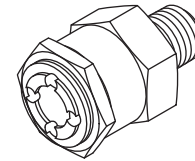

**MFC Flow Control**

**OPTION Z: "EXTERNAL" PILOT OPERATION**

A valve may be ordered factory assembled for "External Pilot" operation by adding the suffix "Z" after the regular model number. 3/8" and 1-1/2" subplate valves are manufactured so the pilot source can **NOT** be provided through the mounting subplate base. On 1/2" and 1" subplate valves the pilot source can be routed through a pilot ported subplate. On all side ported valves, a pilot source must be provided to each solenoid operator.

**OPTIONAL O-RING MATERIALS:**

Unless otherwise specified, all 1/4" and 3/8" soft seal valves come standard with Viton O-rings and all 1/2", 3/4", 1", 1-1/2" and 2" soft seal valves come standard with Buna-N O-rings. If a different material is required, use the dash numbers following the basic valve numbering code. In the example, model RY3G-2 will have Silicon O-rings installed for a low temperature application. On valves larger than 1" consult factory on availability of O-ring materials.

Dash No.	O-ring Description	Temperature Rating
-1	Neoprene for freon	-40°F to 225°F
-2	Silicon	-80°F to 400°F
-3	Viton for most aromatic gases	-20°F to 400°F, 600°F for short time
-4	Butyl Rubber	-60°F to 200°F
-5	Teflon	-250°F to 450°F
-7	Urethane, 70 Durometer	-65°F to 200°F
-9	Buna-N	-40°F to 250°F

We are constantly researching O-ring materials to evaluate performance and durability in the AAA valve product line. Above is a compilation of the most commonly requested O-ring materials and the associated dash number. If you have a particular application that requires an O-ring material that is not listed, please contact us. Since we utilize standard O-ring dimensions in our valves, we can respond to the most obscure O-ring material request.

**Note:** On standard solenoid model valves, the solenoid operator plunger seat is Viton. Solenoid operators must be externally piloted when using gases not compatible with seal material. Consult factory for special plunger seat material.

**FLOW PATTERN:**

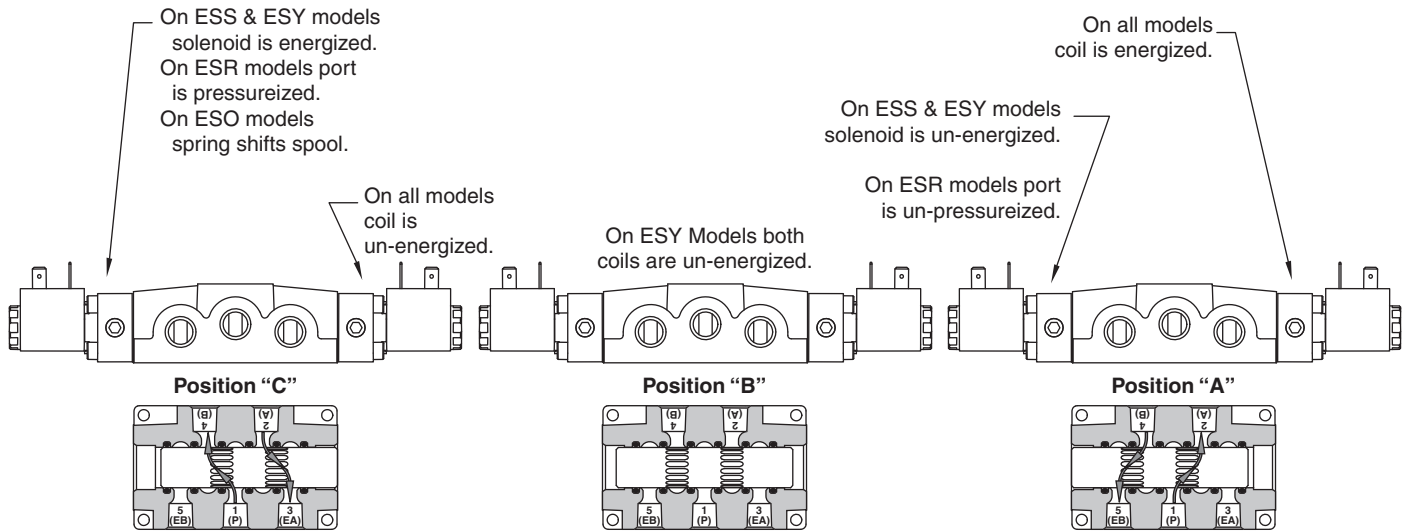

**1/4" through 1":** When a solenoid is energized causing the internal spool to shift, port 1 will connect to the port closest to the energized coil. The furthest port will connect to the appropriate exhaust port.

**1-1/2" and 2":** These larger valves use a "Piggy-Back" valve mounted to the top of the larger valve. When a solenoid is energized causing the internal spool to shift, port 1 will connect to the port closest to the energized coil. The furthest port will connect to the appropriate exhaust port.

**INTERNALLY AND EXTERNALLY PILOTED SOLENOID VALVES:**

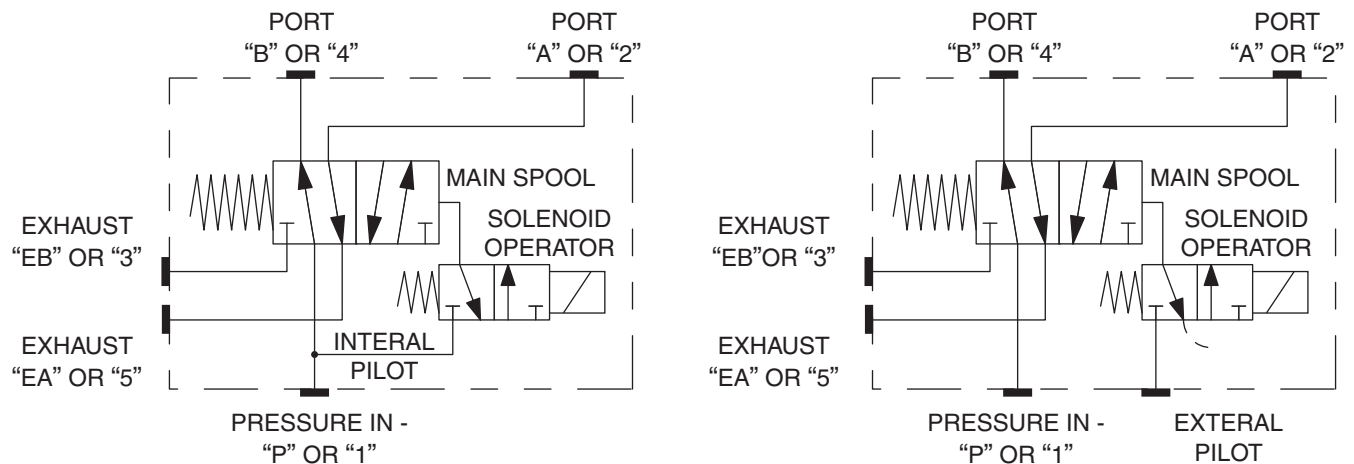

The diagram shows how AAA solenoid valves obtain their shifting power by tapping into the valve inlet inside the valve itself. If inlet pressure is above or below the limits stated by the operator style code, the valve must make use of an outside source of shifting power. It should be factory ordered with suffix "Z" following the regular model number and will be furnished with the electric operator connected to an external pilot pressure port as shown in the diagram above (E.g. ESO4Z 24 vdc).

**CONVERTING TO EXTERNAL PILOT OPERATION**

A valve may be ordered factory assembled for "External Pilot" operation by adding the suffix "Z" after the regular model number; or can be changed to "External Pilot" operation in the field as follows (This operation must be performed on each solenoid operator.)

Remove 4 screws holding the solenoid structure to the main body and remove the entire solenoid assembly. Rotate the entire solenoid assembly 180° and re-mount on the body. Remove the 1/8" plug and connect a source of external pilot pressure, 50 PSI to 150 PSI, to the external pilot port of each solenoid structure. Stamp the name tag with a "Z" to indicate "External Pilot" operation. External pilots can not be brought through the subplate on field conversions.

## AIR FLOW RATINGS AND VALVE SHIFT TIME:

Test for the determination of flow-rate characteristics conforms to ISO 6358, *Pneumatic fluid power - Components using compressible fluids - Determinations of flow-rate characteristics*. These tests were conducted on AAA valves at the Fluid Power Institute Testing Laboratories of the Milwaukee School of Engineering.

**RATED FLOW.** Flow factor tests were made with the valve outlet vented to atmosphere and flow in the sonic region. The average flow factor was calculated from tests over a range of inlet pressures. The factor was then used to calculate expected flow at 100 PSIG. Cv values were calculated by graphing the flow (scfm) versus the square root of change in pressure across the valve. A line was fitted to this graph and the resulting slope is the Cv value. Cv uses the theoretical flow (scfm) through the valve when the differential pressure between the inlet and outlet is equal to 1 psi. **We have never lost an application based on either flow or durability.**

Body Style	Rated Flow					
	2	3	4	6*	8*	12*
Port Size	1/4"	3/8"	1/2"	3/4"	1"	1-1/2"
SCFM Flow	73.9	97.1	215.0	446.9	477.7	1627
Cv Factor	1.6	2.4	5.0	10.4	11.1	37.8

\*Tested before the published ISO standards. Cv's were calculated using previous data.

SCFM flow in the above table was calculated for 70 PSIG then converted to 100 PSIG (114.7 PSIA) inlet pressure. At other inlet pressures, SCFM flow will be in proportion to PSIA inlet pressure.

Example: Size 3P at 80 PSIG (94.7 PSIA) inlet pressure.  
Ratio of 94.7 to 114.7 is  $94.7 \div 114.7 = 0.826$   
Flow at 80 PSIG =  $0.826 \times 97.1 = 80.2$  SCFM.

### LIMITATIONS ON VACUUM OPERATION

The five main ports on AAA valves can be operated on industrial vacuum to 28" Hg, based on a 30" barometer. O-rings between all ports give tight sealing. While AAA valves are basically 4-way, they can be used for 3-way service by plugging the unused port 2 or 4.

To use solenoid controlled models for vacuum service, they must be ordered with Option "Z" or field converted for "External Pilot" operation. An external source of air pressure, 50 PSI to 150 PSI, must be available for pilot pressure. Field conversion is explained with each model listing.

### INTERNALLY PILOTED SOLENOID VALVE TESTING

Standard solenoid models are assembled for "Internal Pilot" operation; that is, they derive shifting pressure for the spool from the valve inlet port. When testing an internally piloted solenoid valve, do not let air free flow through the cylinder port. This flow is normally so great, that back pressure to shift the spool can not be adequately generated. To test an internally piloted valve, either plug the cylinder port, place a muffler in the cylinder port or attach the cylinder port to a short piece of hose to generate a slight back pressure to shift the valve.

### MOUNTING OF VALVES

AAA valves may generally be mounted in any position. But for safety, any valve which does not have springs or detents to hold the spool in position should be mounted with the spool horizontal unless pressure is continually applied to hold the spool in position.

**RESPONSE TIME.** Shifting time of pneumatic directional control valves was measured in accordance with ISO 12238:2001, *Pneumatic fluid power - Directional control valves - Measurement of shifting time*.

With the valve initially shifted to communicate 150 PSI inlet pressure to a blocked cylinder port the total elapsed shifting time was measured between the instant of energization of the opposite solenoid and build up of 90% of full steady state flow in the other cylinder port, which was vented to atmosphere. The result is a measure of the "Blocked to Open Shift Time".

In another test, with the valve initially shifted to a port which was vented to atmosphere, the total elapsed time was measured between the instant of energization of the opposite solenoid and build-up of 90% of full steady state pressure in the other cylinder port which was blocked. The result is a measure of "Open to Blocked Shift Time":

Body Style	Response Times in Milliseconds					
	2	3	4	6	8	12
Blocked*	18.0	16.7	23.2	28.7	29.7	123.3
Open†	17.3	16.7	19.3	26.8	27.9	116.3

\*Blocked to Open response time.

†Open to Blocked response time.

The shifting time is quite satisfactory for almost all applications, but for faster response a larger orifice can be supplied on special order.

## SEAL KITS:

- ERKV-3:** One kit required for each 1/4" or 3/8" valve. Includes six V-39 Viton body O-rings, two EMG3 Buna-N solenoid gaskets, two ECG3 composition end cap gaskets, two V-565 Buna-N Namur mounting O-rings, one PBG3 gasket, one PBG3-1 gasket, five V-92 Buna-N subplate O-rings and two V-93 Buna-N subplate pilot O-rings (Seals used determined by valve model and style).
- ERKV-4:** One kit required for each 1/2" valve. Includes six V-6 Buna-N body O-rings, two EMG3 Buna-N solenoid gaskets, two ECG48 composition end cap gaskets, five V-110 Buna-N subplate O-rings, two V-29 Buna-N subplate pilot hole O-rings (Seals used determined by valve model and style).
- ERKV-8:** One kit required for each 3/4" or 1" valve. Includes six V-30 Buna-N body O-rings, two EMG3 Buna-N solenoid gaskets, two ECG48 composition end cap gaskets, five V-90 Buna-N subplate O-rings, two V-89 Buna-N subplate pilot hole O-rings (Seals used determined by valve model and style).
- ERKV-16:** One kit required for each 1-1/2" or 2" valve. Includes six V-123 Buna-N body O-rings, two V-124 Buna-N end cap O-rings, two V-89 Buna-N end cap pilot O-rings, five V-125 Buna-N subplate O-rings, two V-89 Buna-N subplate pilot O-rings (Seals used determined by valve model and style). To repair piggy back valve, use ERKV-3.
- VGK-3:** AAA valve grease to lubricate body O-rings during valve overhaul (Each seal repair kit does supply enough grease for complete seal replacement).

## REPLACEMENT COMPONENTS:

**Consult Factory.** All AAA valves are designed for rugged applications. But sometimes unforeseen damage does occur. Please contact us for broken clevis', handles, tired springs or any other component that appears to be working less than optimum.

## STANDARD SOLENOID ACCESSORIES:

### DIN CAPS

There are several styles of DIN caps. When ordering LED Indicator types, you must specify voltage of solenoid coil (E.g. DCL-120/60). All caps listed in table are for 11mm/Industrial Form B coils, consult factory for additional forms available. LED Indicator type caps are equipped with surge protection.

**Environmental Rating:** IP 65

Model No.	Style	LED
DCC	1/2" Conduit	no
DCCL	1/2" Conduit	yes
DCG	3/8" Grip	no
DCGL	3/8" Grip	yes
DC3M*	3 Meter Cord	no
DC3ML*	3 Meter Cord	yes

\*Consult factory for other lengths of cord.

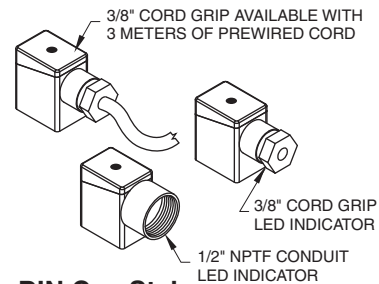

**DIN Cap Styles**

### OPTIONAL COIL NUTS

- V-567 Sintered Bronze Muffler
- V-562 Side Exhaust

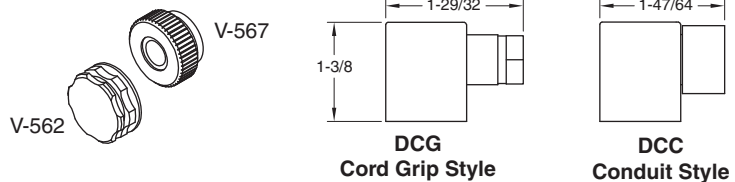

**STANDARD 1/4" THROUGH 2"  
SOLENOID: ESO, ESR, ESS, ESY**

**SEMI-DIMENSIONAL DRAWINGS:**

**MODELS: ESO2, ESR2, ESO3 & ESR3**

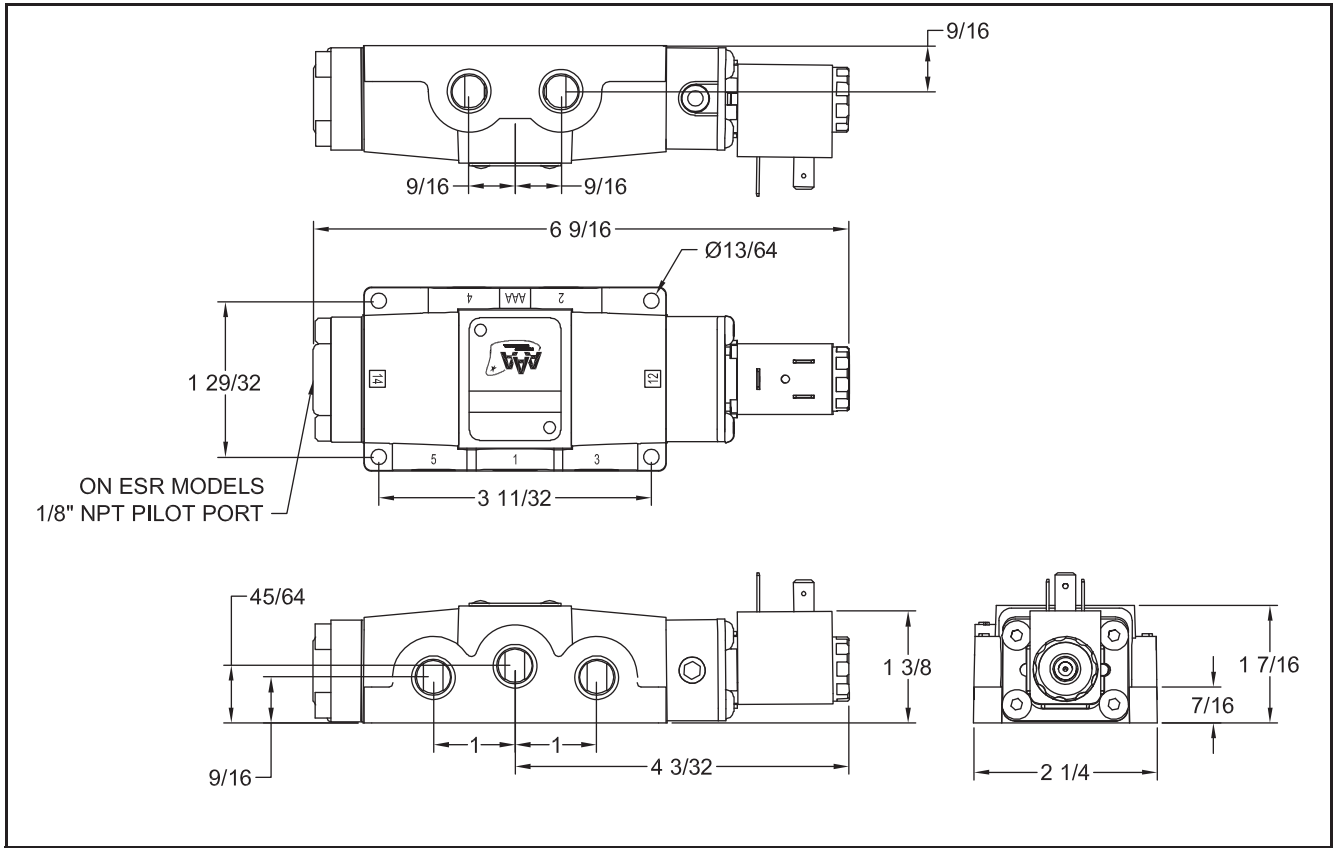

**MODELS: ESO3P & ESR3P**

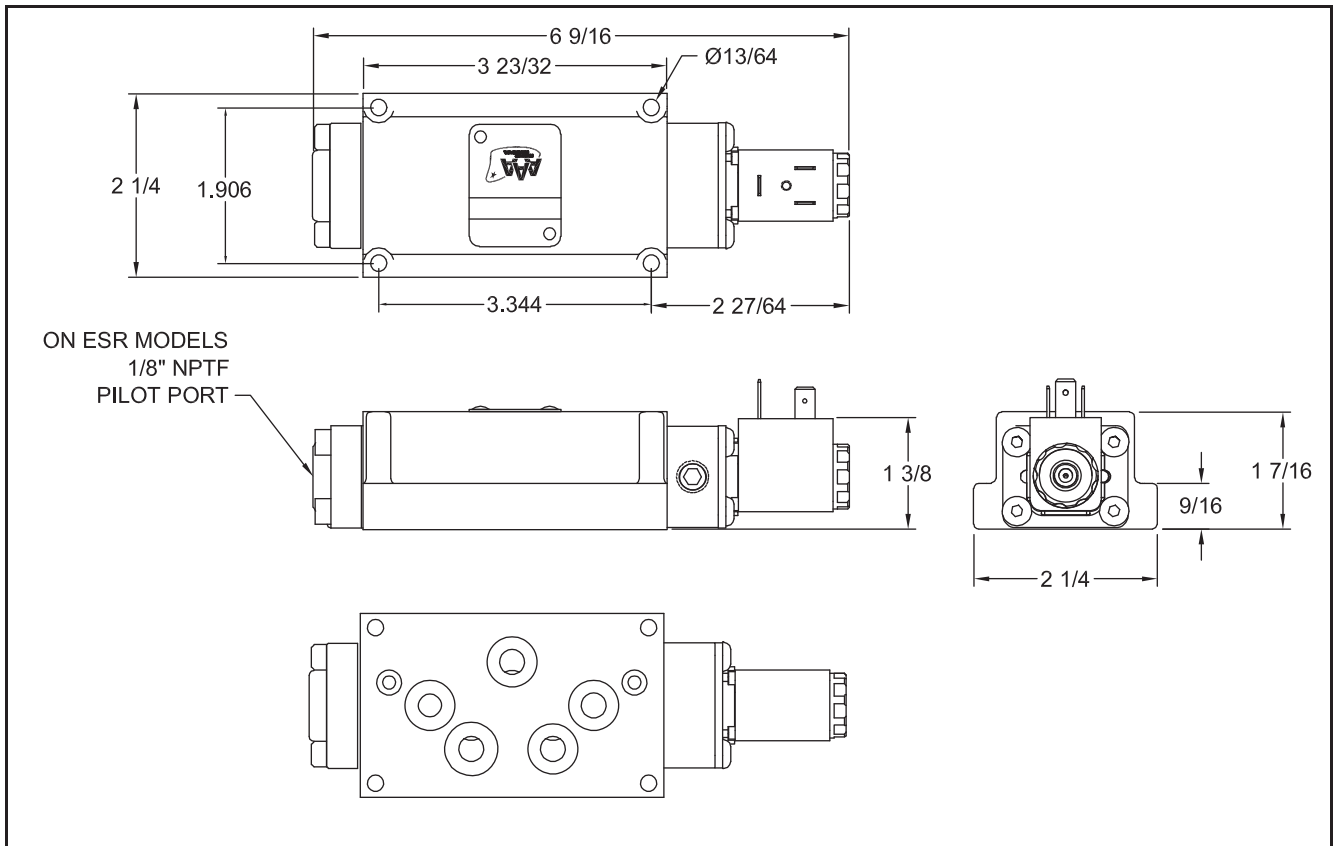

**MODELS: ESS2 & ESS3**

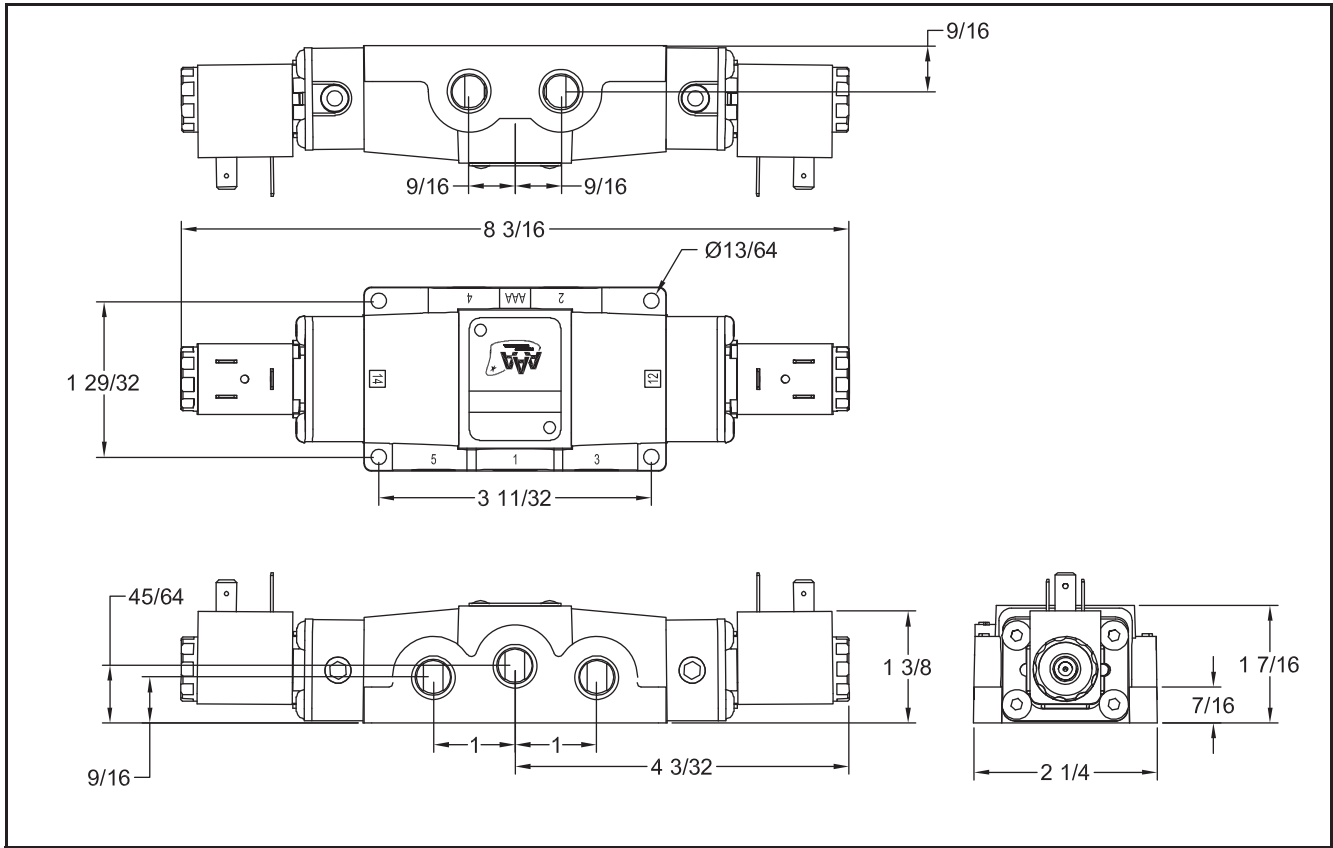

**MODELS: ESS3P**

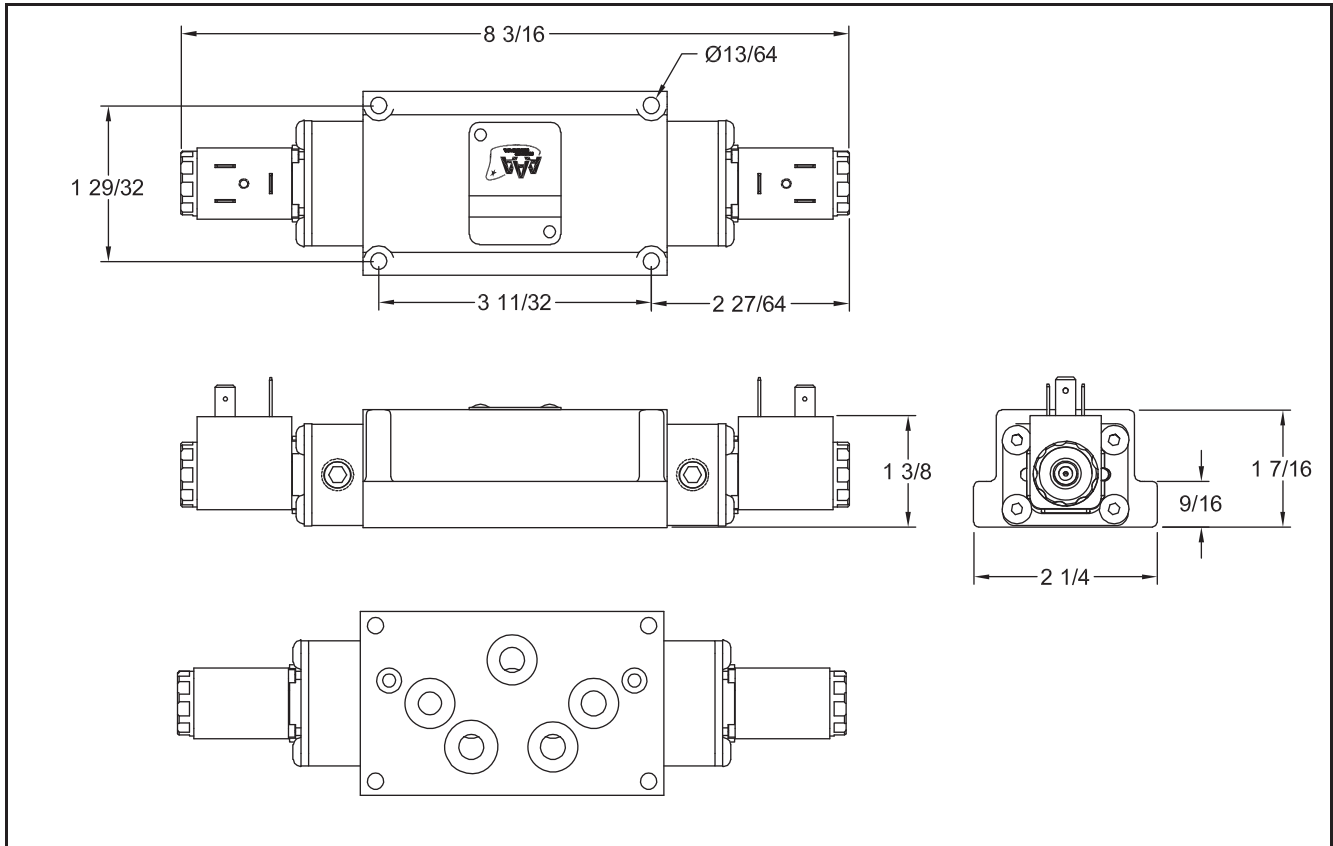

**STANDARD 1/4" THROUGH 2"  
SOLENOID: ESO, ESR, ESS, ESY**

**MODELS: ESY2 & ESY3**

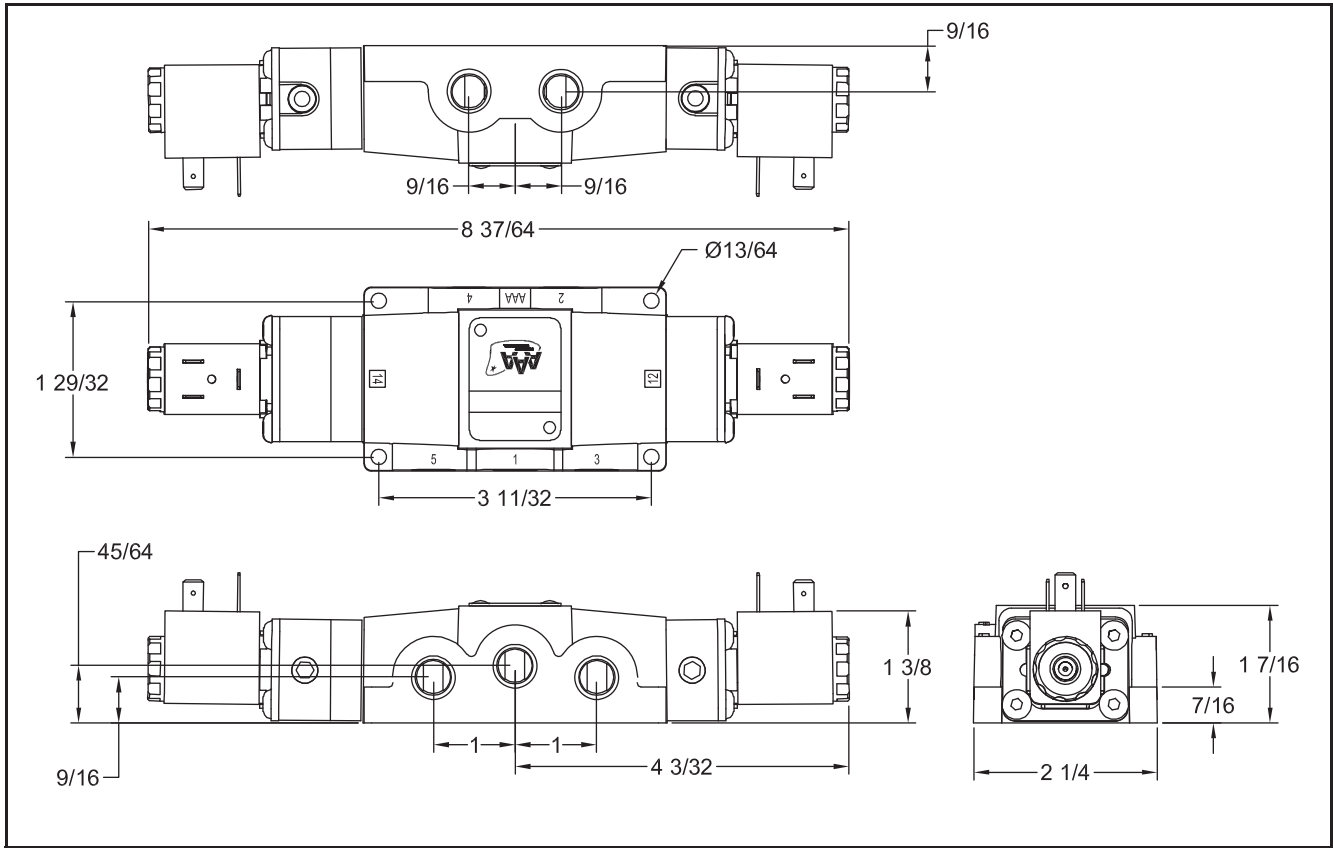

**MODELS: ESY3P**

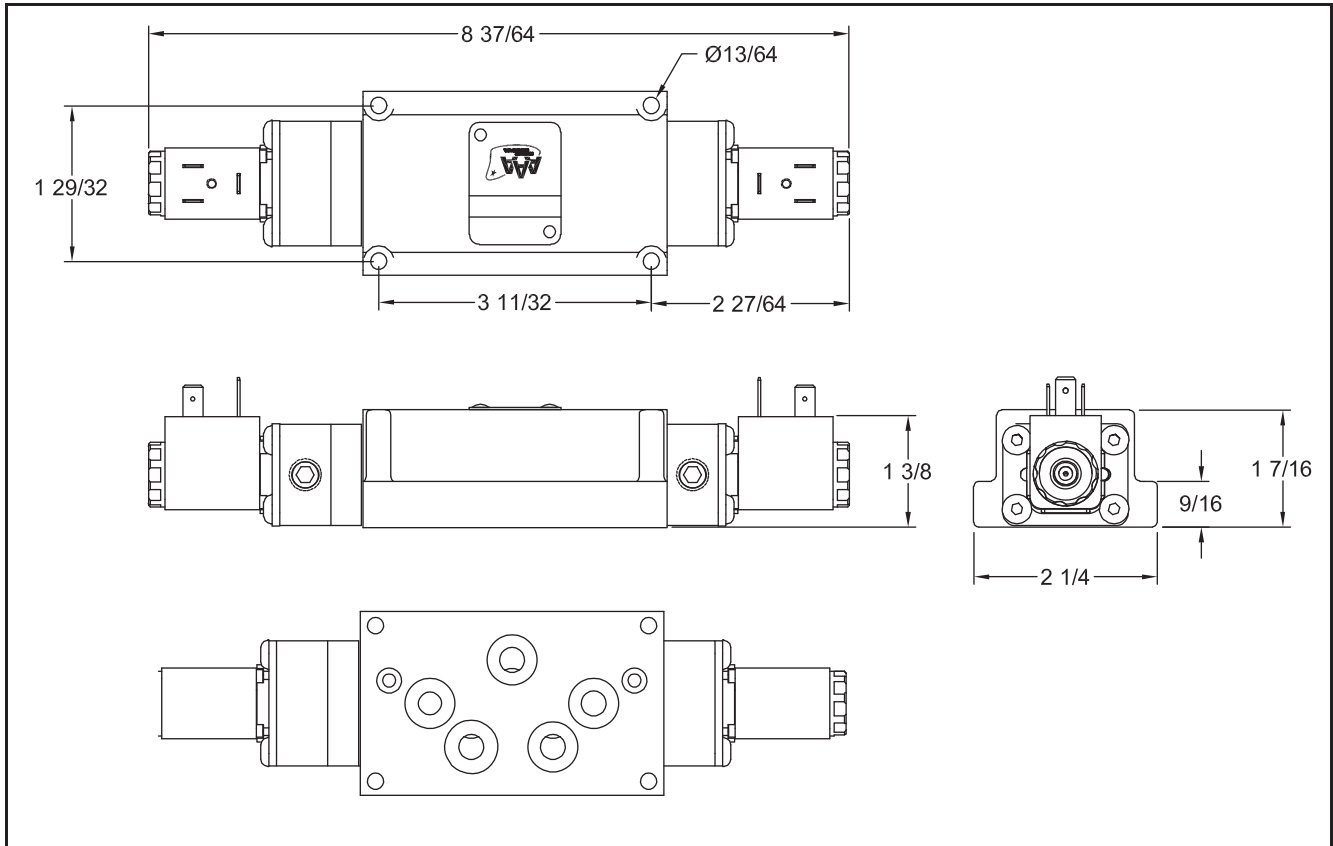

**MODELS: ESO4, ESR4, ESO4P & ESR4P**

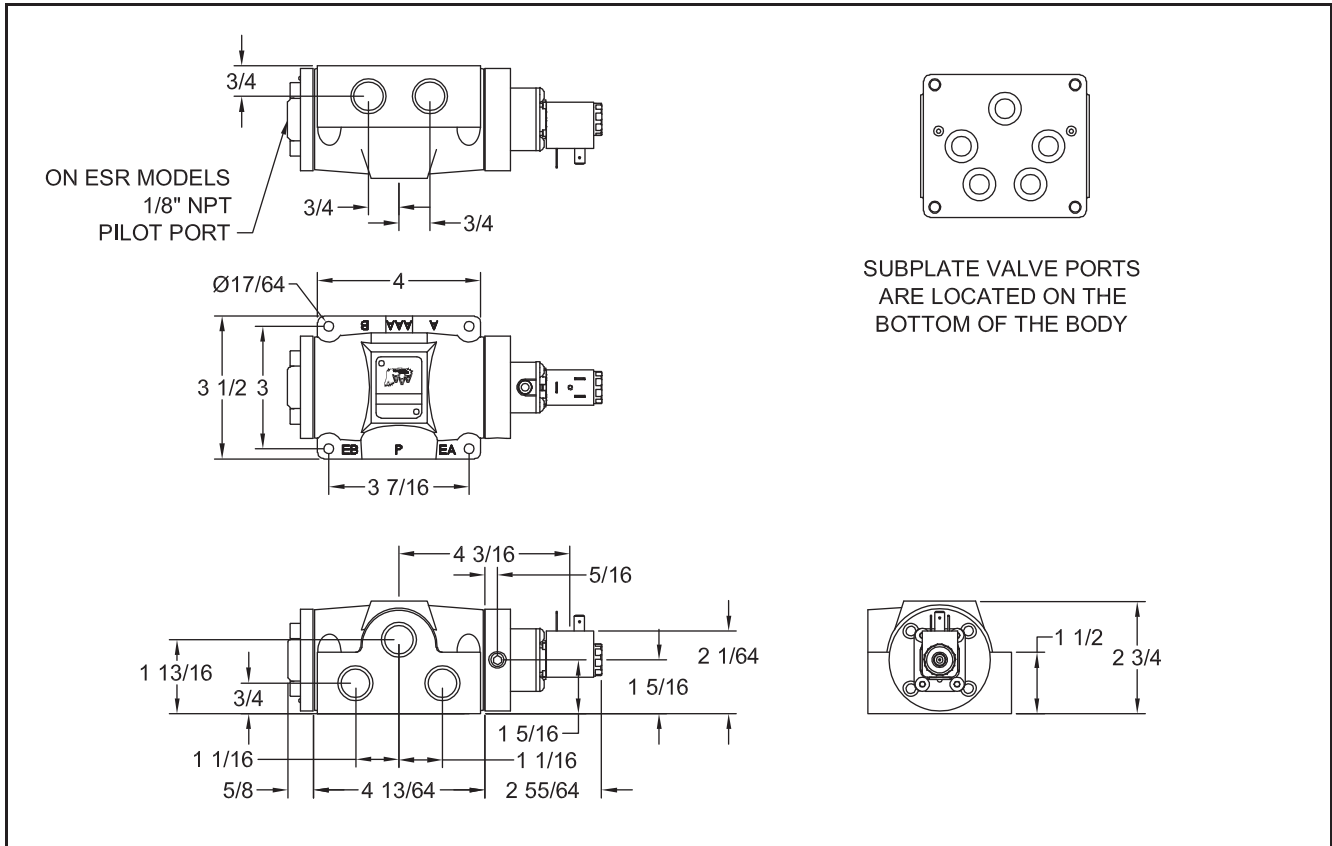

**MODELS: ESS4, ESY4, ESS4P & ESY4P**

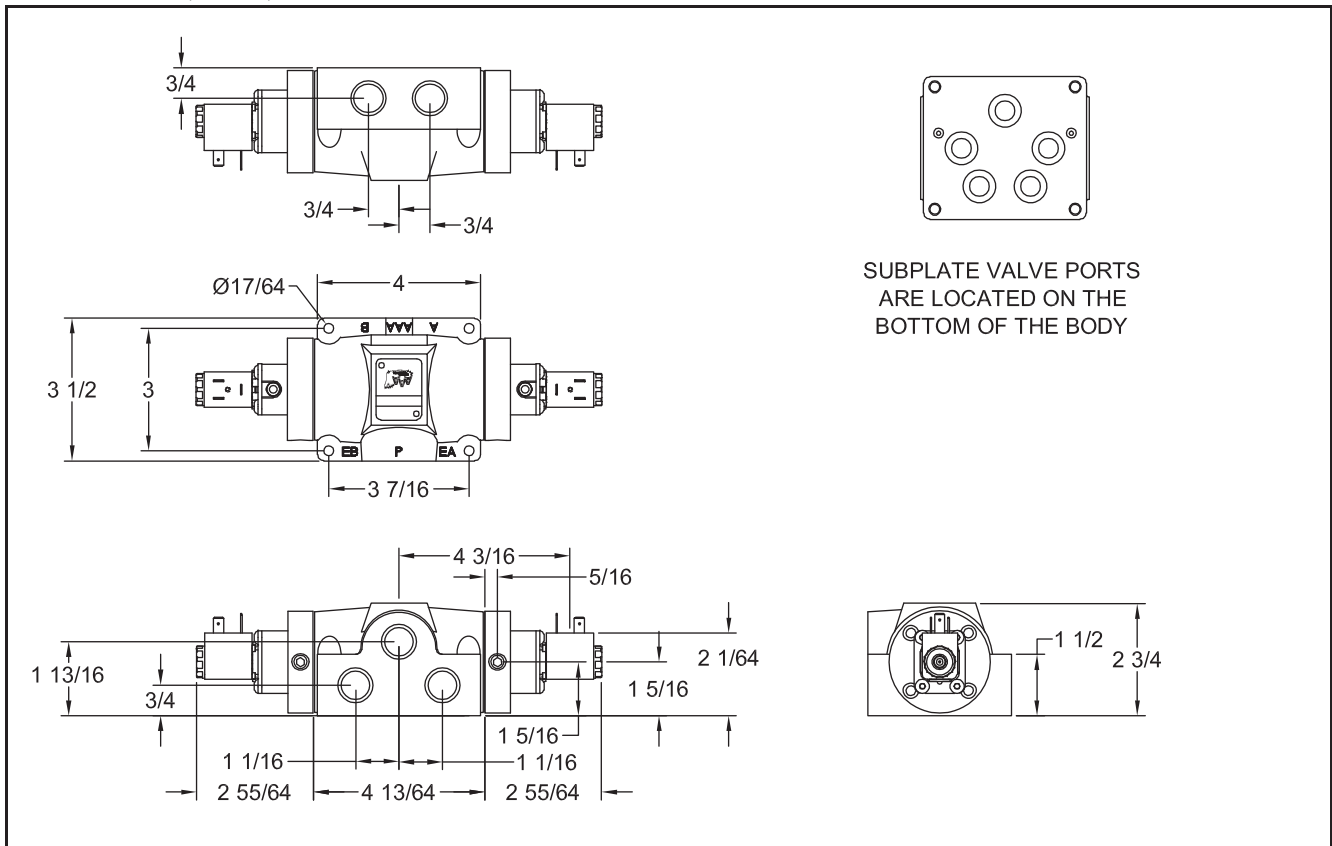

**STANDARD 1/4" THROUGH 2"  
SOLENOID: ESO, ESR, ESS, ESY**

**MODELS: ESO6, ESR6, ESO8, ESR8, ESO8P & ESR8P**

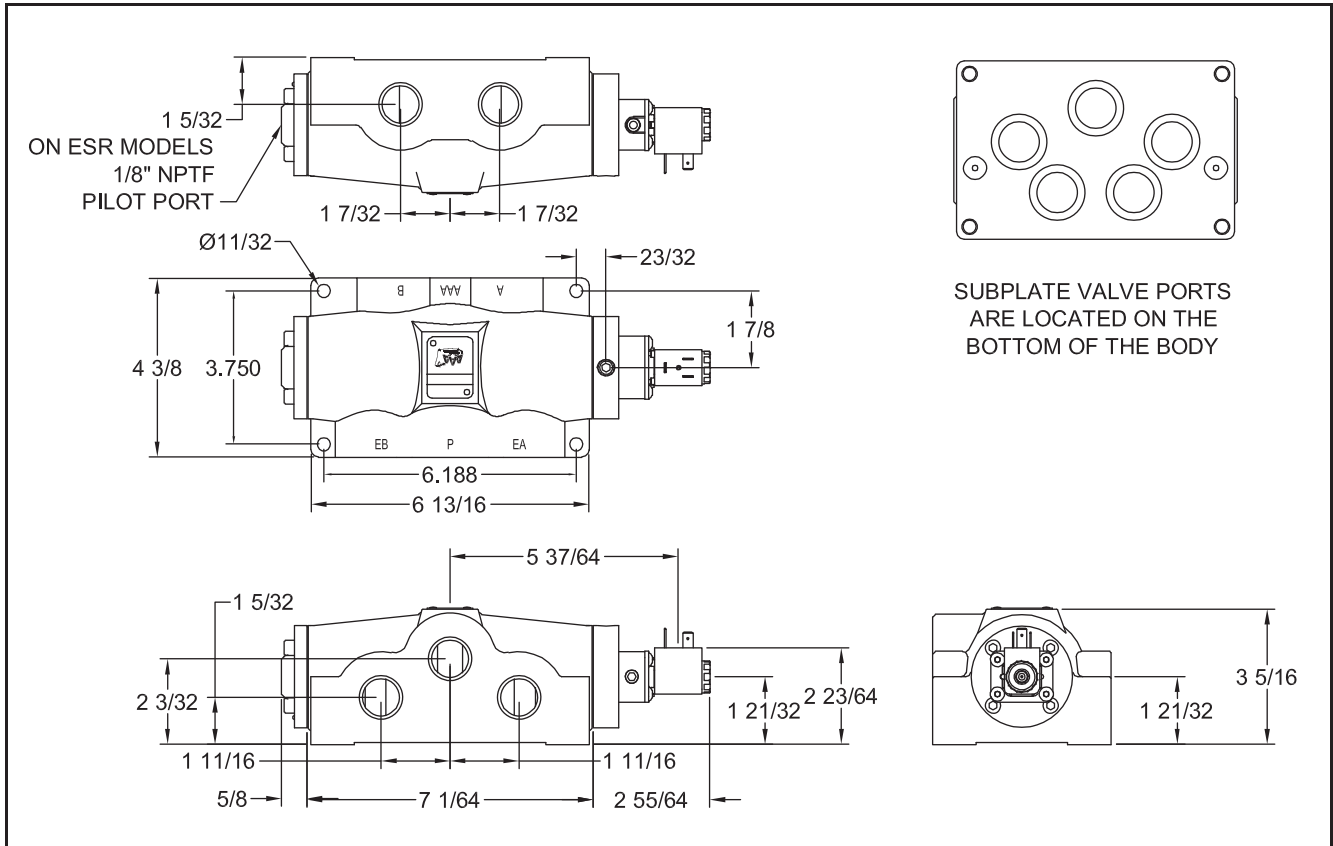

**MODELS: ESS6, ESY6, ESS8, ESY8, ESS8P & ESY8P**

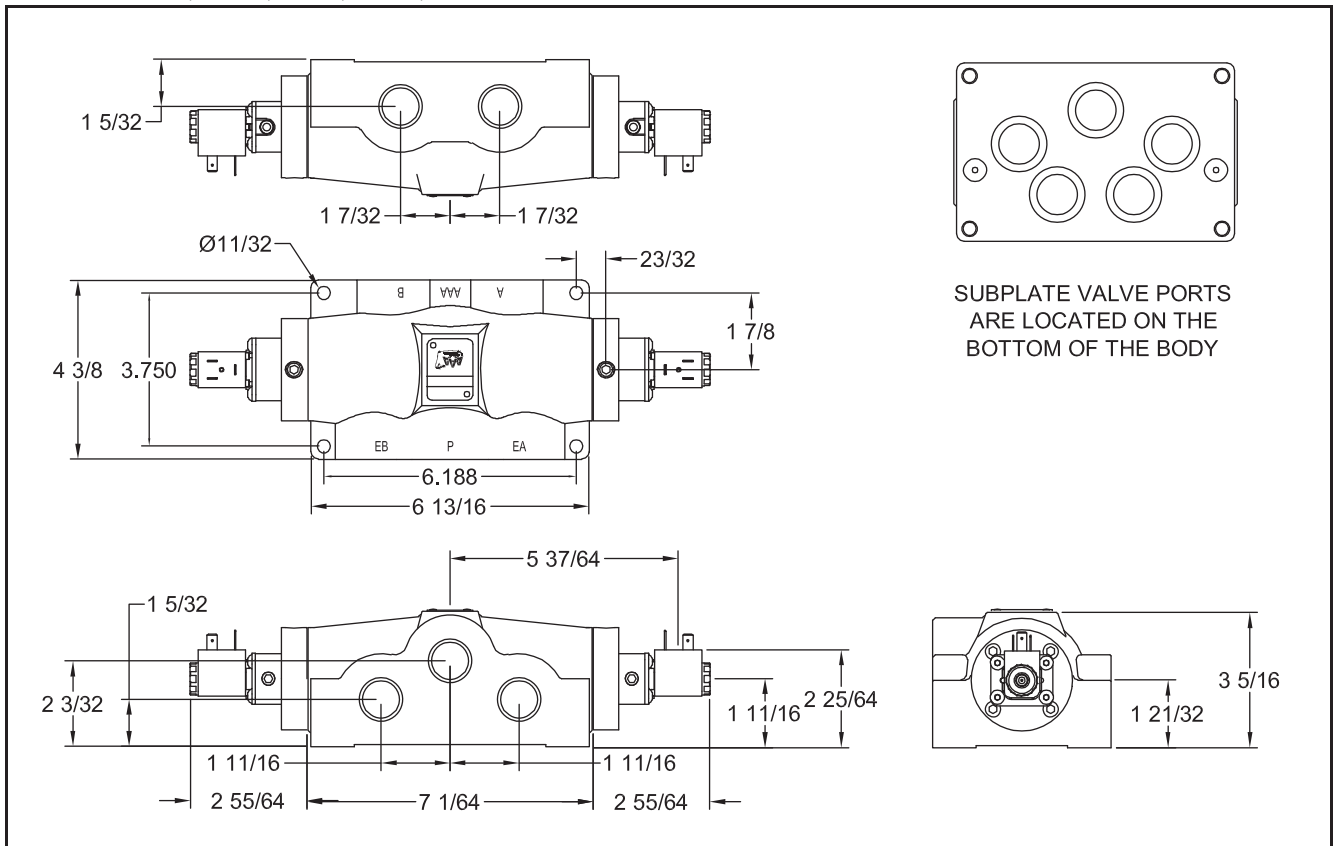

**MODELS: ESO12, ESR12, ESO16P & ESR16P**

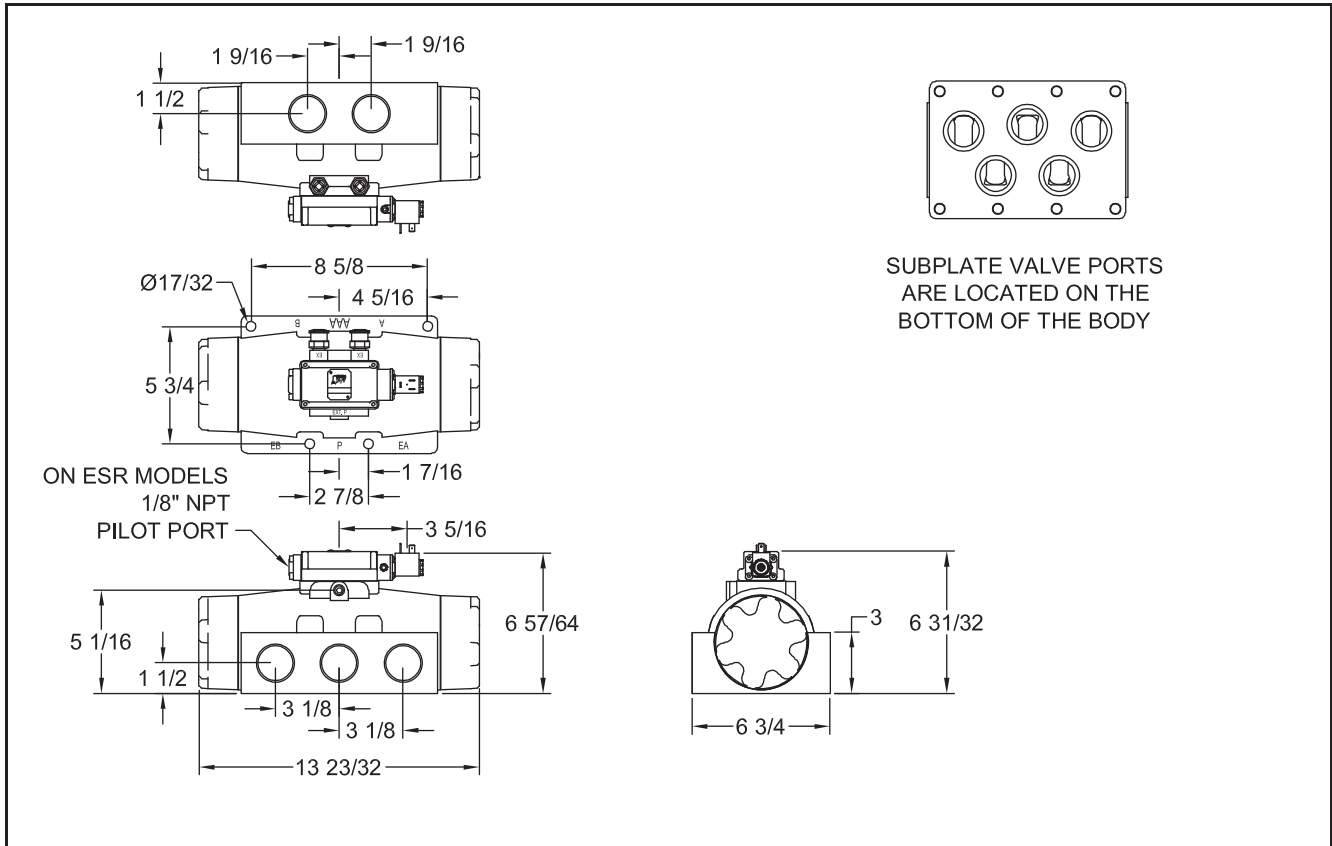

**MODELS: ESS12, ESY12, ESS16P & ESY16P**

