

## *PALM BUTTON CONTROLLED AIR VALVES*

4-WAY: VACUUM TO 250 PSI

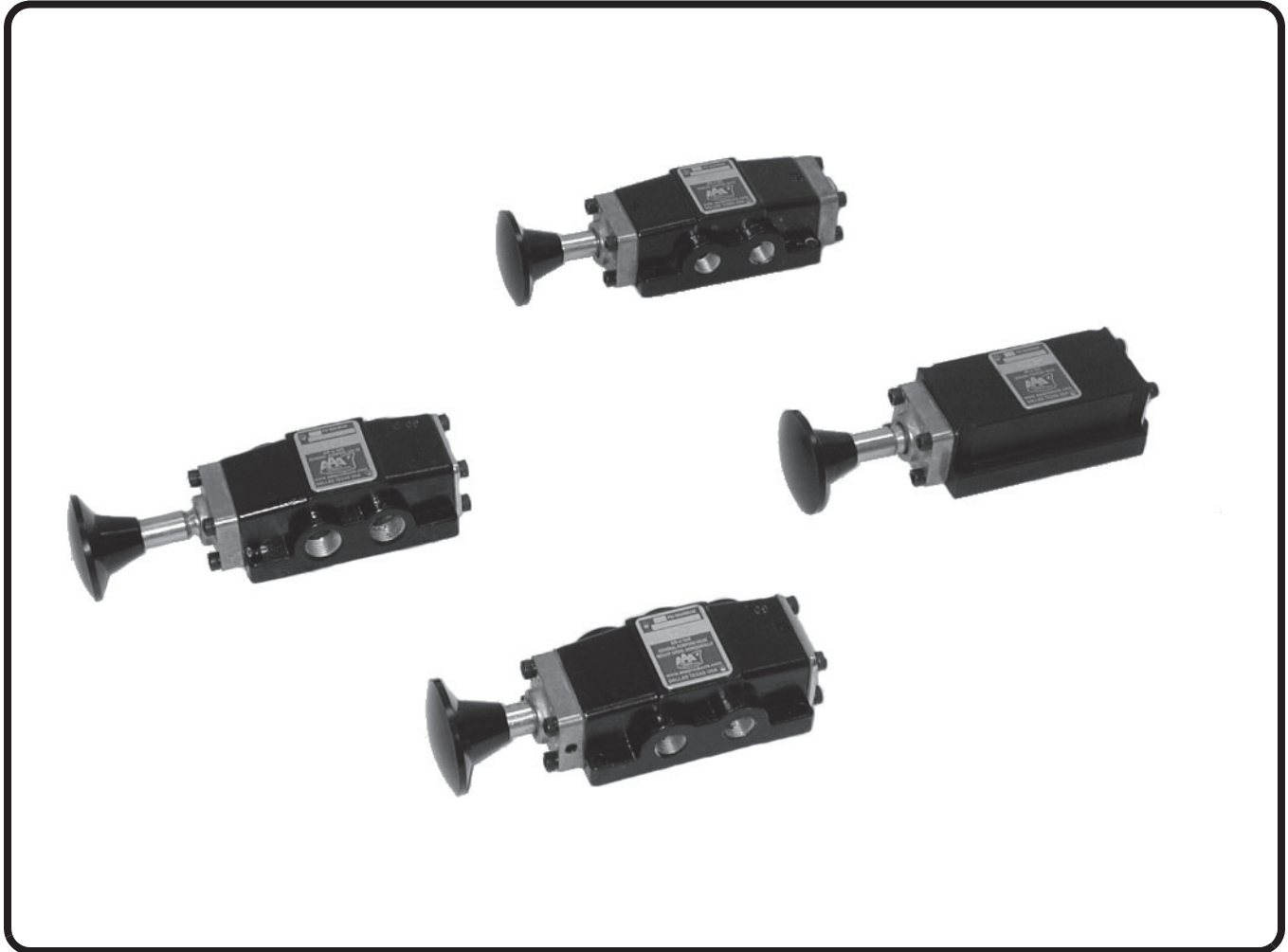

### **PART NUMBER STRUCTURE:**

- Part 1:** The basic part number of an AAA valve is fairly simple to understand. The first part is both an operator style and valve operation. This position describes not only how the valve shifts positions but also what shifts the spool.
- Part 2:** The second portion is the valve port size and body style. This portion describes whether the valve is a threaded side ported body or a bottom bored subplate body.
- Part 3:** The third part of the part number structure is the spool configuration. Normally only needed on three position valves, the spool configuration defines the flow at center position. You can have a spool other than the standard "Closed Center" on two position valves; however, the transitional flow is normally not needed for most applications.
- Part 4:** The fourth position of the part number structure is used to specify valve options. You can specify pin lock, lockout or panel mount by choosing options available for the valve configuration you need.
- Part 5:** The final position allows you to specify different O-rings used in the main valve body. You choose the O-ring most suited for your application. This specification applies to the body O-rings only.

# KE3PGR-5

## 1 Operator Style

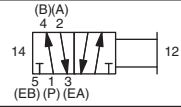
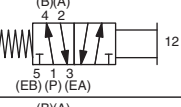
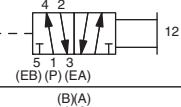
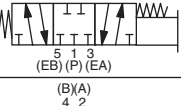
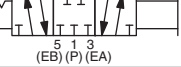
Code	Description	Symbol
KE	2-position, friction positioned. Spool stays in any position when knob is released.	
KO	2-position, spring returned spool. Spool returns to position "C" when the knob is released.	
KR	2-position, pilot returned spool. Spool returns to position "C" from auxiliary control valve furnished by the user (or by knob).	
KY	3-position, spring centered. When knob is released, spool shifts to center (position "B").	
KD	3-position, friction position, positive detent in all positions. Spool stays in position when knob is released.	

## 2 Body Style

### Side Ported

2 = 1/4" NPTF  
3 = 3/8" NPTF

### Subplate Mounted

3P = 3/8" flow

## 3 Spool Configuration (Normally on 3-position valves, 2-position valves use a closed center spool)

blank = Closed center, all ports are blocked in the center position.

D = Regenerative center, ports 2 & 4 are connectect to port 1, ports 3 & 5 are blocked.

G = Float center, port 2 is connected to port 3, port 4 is connected to port 5, port 1 is blocked.

## 4 Valve Options

blank = No options selected.

E = Pin lock.

LO = Lockout.

Q = 2-position spool detent (available only on model KD).

R = Panel mount (available only on body styles 2 & 3).

SS = All stainless steel construction (KE2, KE3, KO2 & KO3 Only).

U = Factory installed muffler/flow controls in ports 3 and 5 (body styles 2, 3 & 4 only).

## 5 Valve O-Ring Option (Only applies to valve body O-Rings)

blank = Viton for body styles 2, 3 & 3P, Buna-N for body styles 4, 6, 8, 12, 4P, 8P & 16P.

-1 = Neoprene for freon (-40°F to 225°F).

-2 = Silicon (-80°F to 400°F).

-3 = Viton for most aromatic gases (-20°F to 400°F, 600°F for short time).

-4 = Butyl Rubber (-60°F to 200°F).

-5 = Teflon (-250°F to 450°F).

-7 = Urethane, 70 Durometer (-65°F to 200°F).

-9 = Buna-N (-40°F to 250°F).

## ***GENERAL INFORMATION***

Palm button models are operated with a palm button that directly connects to the spool. The standard position of the palm button for a 3-position valve is the center of the valve (Position “B”). To fully shift the valve, the palm button is pushed away from the operator (Position “A”) or pulled towards the operator (Position “C”). On 2-position valves, there is no positive lock for centering the spool (Position “B”).

### **OPERATOR STYLE CODE:**

- KE:** 2-position, friction position, manual return. Spool stays in any position when knob is released (See the detented version for mobile or vertical valve mounting).
- KO:** 2-position, spring returned spool. Spool returns to position “C” when knob is released.
- KR:** 2-position, pilot returned spool. Spool returns to position “C” from auxiliary control valve furnished by the user or by pulling the knob to position “C”. Return shift pressure should be 25 PSI or greater.
- KY:** 3-position, spring center. Spool returns to center, position “B”, when knob is released.
- KD:** 3-position, friction position, positive detent in all positions. Spool stays in position when knob is released. Additional shifting force is required to initiate spool shifting.

### **BODY STYLE:**

**SIDE PORTED:** Side ported valves can be installed inline. These valves have standard female “National Pipe Threads” to connect directly to installed air lines. The standard pipe sizes are 1/4" and 3/8" NPTF.

**SUBPLATE MOUNTED:** Subplated valves require a mounting base. This mounting base is pre-plumbed to existing control lines. Due to the nature of all the plumbing lines fixed to a mounting base, replacing subplate mounted valves is rapid and quick. All connections, including “Pilot Return” port, if used, are made through O-ring sealed holes in the base of the valve through a subplate. O-ring seals and mounting screws are furnished with each subplate valve. Because the connections to a base mount can be of any size and configuration, subplate mounted valves are assigned a designation derived from a basic valve body size. A 3P size subplate valve will have the same flow characteristics as a 3/8" NPTF side ported valve body.

### **SPOOL CONFIGURATION (FOR 3-POSITION VALVES):**

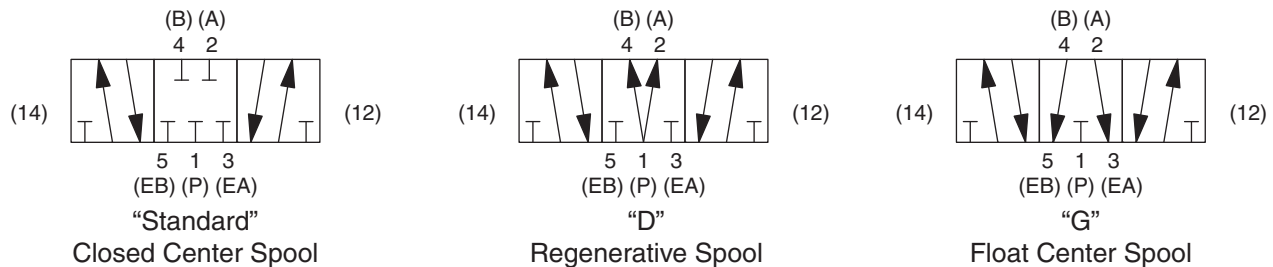

**STANDARD:** Most valves are supplied with a “Closed Center” spool. In the center position, all ports are blocked. If a valve is only a 2-position valve, the actual function of the center position is not critical. So most 2-position valves are “Closed Center”. Some designs do require softer transitions, so we offer alternate spool configurations on 2-position valves.

**REGENERATIVE:** Spool Option “D”. In the center position or during transition, ports 2 and 4 are connected to port 1. We call this a “Regenerative” spool since both cylinder ports 2 and 4 are supplied with pressure and flow from port 1.

**FLOAT CENTER:** Spool Option “G”. In the center position or during transition, port 2 is connected to port 3 and port 4 is connected to port 5. We call this a “Float Center” spool since both standard cylinder ports 2 and 4 are vented to an exhaust port and no pressure or flow from port 1 is supplied.

## VALVE OPTIONS:

### OPTION E: PIN LOCK

This option converts a single hand operated valve into a two hand operated valve required for some safety applications. To operate, user pulls the pin lock out while simultaneously shifting the valve. The user then releases the pin. The pin lock is spring loaded and snaps into the next available detent when the valve is shifted. On two position valves (KE, KO & KR), the pin will only snap in positions "A" and "C". On three position valves (KY, the pin will also snap in the "B" position. Contact the factory if you want valves that only snap in different spool positions. Not available on KD models.

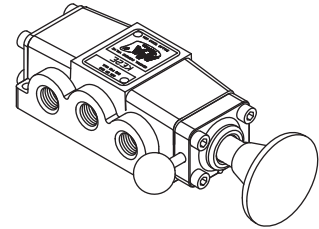

### OPTION LO: LOCK OUT

This option allows the valve to lock into position. On two position valves (KE, KO and KR), the lock-out position is position "C". On three position valves (KY), the lock-out position is position "B". Contact the factory if you want valves that lock-out in different spool positions. Not available on KD models. Valve shown with optional lock and optional multi-lockout hasp.

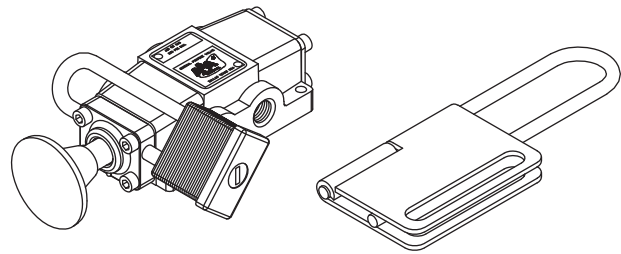

### OPTION Q: TWO POSITION DETENT

This option is available on KD models only. Spool stays in position "A" or "C" when palm button is released. This is a 2-position version of the model KD where there is no center position detent. Additional shifting force is required to initiate spool shifting.

### OPTION R: PANEL MOUNT

This option is only available on body styles 2 and 3. This option allows the valve to be mounted on a panel up to 1/4" thick through a 7/8" diameter hole.

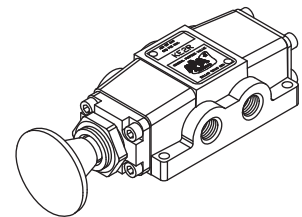

### OPTION SS: STAINLESS STEEL

This option is only available on models KE and KO with body styles 2 and 3. This option allows the valve to be used in harsh, wash down environments. Entire construction is stainless steel, even the nameplate and screws. Soft seal construction with Viton O-ring seals in body grooves. Can be used on compressed air or gases compatible with 316 stainless steel and Viton seals.

Physical dimensions, flow diagrams and other specifications are the same as standard valves.

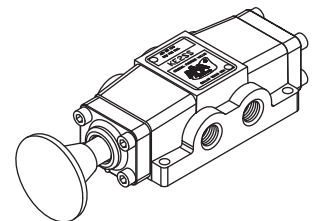

### OPTION U: EXHAUST FLOW CONTROLS

Available only on body styles 2, 3 and 4. A Model MFC flow control, listed on page 146, is screwed into each exhaust port, giving meter-out speed control of an associated air cylinder or air motor in both directions of travel. MFC flow controls not only give adjustable speed control but have a built-in muffler to reduce exhaust noise.

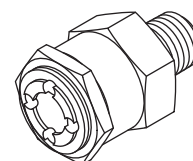

**MFC Flow Control**

## OPTIONAL O-RING MATERIALS:

Unless otherwise specified, all 1/4" and 3/8" soft seal valves come standard with Viton O-rings and all 1/2", 3/4", 1", 1-1/2" and 2" soft seal valves come standard with Buna-N O-rings. If a different material is required, use the dash numbers following the basic valve numbering code. As an example, model SY3G-2 will have Silicon O-rings installed for a low temperature application. On valves larger than 1", consult factory on availability of O-ring materials.

Dash No.	O-ring Description	Temperature Rating
-1	Neoprene for freon	-40°F to 225°F
-2	Silicon	-80°F to 400°F
-3	Viton for most aromatic gases	-20°F to 400°F, 600°F for short time
-4	Butyl Rubber	-60°F to 200°F
-5	Teflon	-250°F to 450°F
-7	Urethane, 70 Durometer	-65°F to 200°F
-9	Buna-N	-40°F to 250°F

We are constantly researching O-ring materials to evaluate performance and durability in the AAA valve product line. Above is a compilation of the most commonly requested O-ring materials and the associated dash number. If you have a particular application that requires an O-ring material that is not listed, please contact us. Since we utilize standard O-ring dimensions in our valves, we can respond to the most obscure O-ring material request.

## STANDARD TEMPERATURE RANGE:

Operating temperature is dependent upon the seal materials used. The following are temperatures for standard valves:

1/4" and 3/8" valves use Viton O-rings: -20°F to 400°F, 600°F for short time.

1/2", 3/4", 1", 1-1/2" and 2" valves use Buna-N O-rings: -40°F to 250°F.

**Caution:** If it is possible that the ambient temperature may fall below freezing, the medium must be moisture free to prevent internal damage or unpredictable behavior.

## SHIFTING CHARACTERISTICS:

**1/4" and 3/8":** On KO models, a minimum force of 12 lbs is required to shift the spool against the spring with a functional spool travel of 17/32" and with an over-travel of 1/32". On KY models, a minimum force of 12 lbs is required to shift the spool against the spring in either direction from center. Functional spool travel of 1/4" in either direction from center with an over-travel of 1/32" on each end. On KR models a sufficient force is required to opposing force created by the pilot return. Functional spool travel is 17/32" with an over-travel of 1/32". On KE and KD models, sufficient force to overcome friction and/or detents. Functional spool travel is similar to models described above.

**Operating pressure of the valve may affect the shifting force required.**

## FLOW PATTERN:

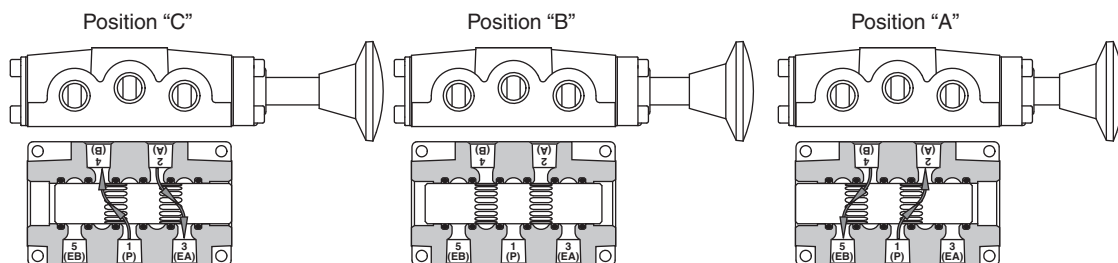

**1/4" through 3/8":** When the palm button is shifted, causing the internal spool to shift, various ports will be connected. If the palm button is in position "A", port 1 will connect to port 2. When the palm button is in position "C", port 1 will connect to port 4. The appropriate exhaust will connect to the un-pressurized port. In position "B", the connection of the ports depend on the style of spool used.

## AIR FLOW RATINGS:

Test for the determination of flow-rate characteristics conforms to ISO 6358, *Pneumatic fluid power - Components using compressible fluids - Determinations of flow-rate characteristics*. These tests were conducted on AAA valves at the Fluid Power Institute Testing Laboratories of the Milwaukee School of Engineering.

**RATED FLOW.** Flow factor tests were made with the valve outlet vented to atmosphere and flow in the sonic region. The average flow factor was calculated from tests over a range of inlet pressures. The factor was then used to calculate expected flow at 100 PSIG. Cv values were calculated by graphing the flow (scfm) versus the square root of change in pressure across the valve. A line was fitted to this graph and the resulting slope is the Cv value. Cv uses the theoretical flow (scfm) through the valve when the differential pressure between the inlet and outlet is equal to 1 psi. **We have never lost an application based on either flow or durability.**

### Rated Flow

Body Style	2	3
Port Size	1/4"	3/8"
SCFM Flow	73.9	97.1
Cv Factor	1.6	2.4

SCFM flow in the above table was calculated for 70 PSIG then converted to 100 PSIG (114.7 PSIA) inlet pressure. At other inlet pressures, SCFM flow will be in proportion to PSIA inlet pressure.

Example: Size 3P at 80 PSIG (94.7 PSIA) inlet pressure.

Ratio of 94.7 to 114.7 is  $94.7 \div 114.7 = 0.826$

Flow at 80 PSIG =  $0.826 \times 97.1 = 80.2$  SCFM.

## LIMITATIONS ON VACUUM OPERATION

---

The five main ports on AAA valves can be operated on industrial vacuum to 28" Hg, based on a 30" barometer. O-rings between all ports give tight sealing. While AAA valves are basically 4-way, they can be used for 3-way service by plugging the unused port 2 or 4.

## MOUNTING OF VALVES

---

AAA valves may generally be mounted in any position. But for safety, any valve which does not have springs or detents to hold the spool in position should be mounted with the spool horizontal unless pressure is continually applied to hold the spool in position.

## SEAL KITS:

**ERKV-3:** One kit required for each 1/4" or 3/8" valve. Includes six V-39 Viton body O-rings, two EMG3 Buna-N solenoid gaskets, two ECG3 composition end cap gaskets, two V-565 Buna-N Namur mounting O-rings, one PBG3 gasket, one PBG3-1 gasket, five V-92 Buna-N subplate O-rings and two V-93 Buna-N subplate pilot O-rings (Seals used determined by valve model and style).

**VGK-3:** AAA valve grease to lubricate body O-rings during valve overhaul (Each seal repair kit does supply enough grease for complete seal replacement).

## REPLACEMENT COMPONENTS:

**Consult Factory.** All AAA valves are designed for rugged applications. But sometimes unforeseen damage does occur. Please contact us for broken clevis', handles, tired springs or any other component that appears to be working less than optimum.

**STANDARD 1/4" THROUGH 2"  
PALM BUTTON: KE, KO, KR, KY, KD**

**SEMI-DIMENSIONAL DRAWINGS:**

**MODELS: KE2, KO2, KD2, KE3, KO3 & KD3**

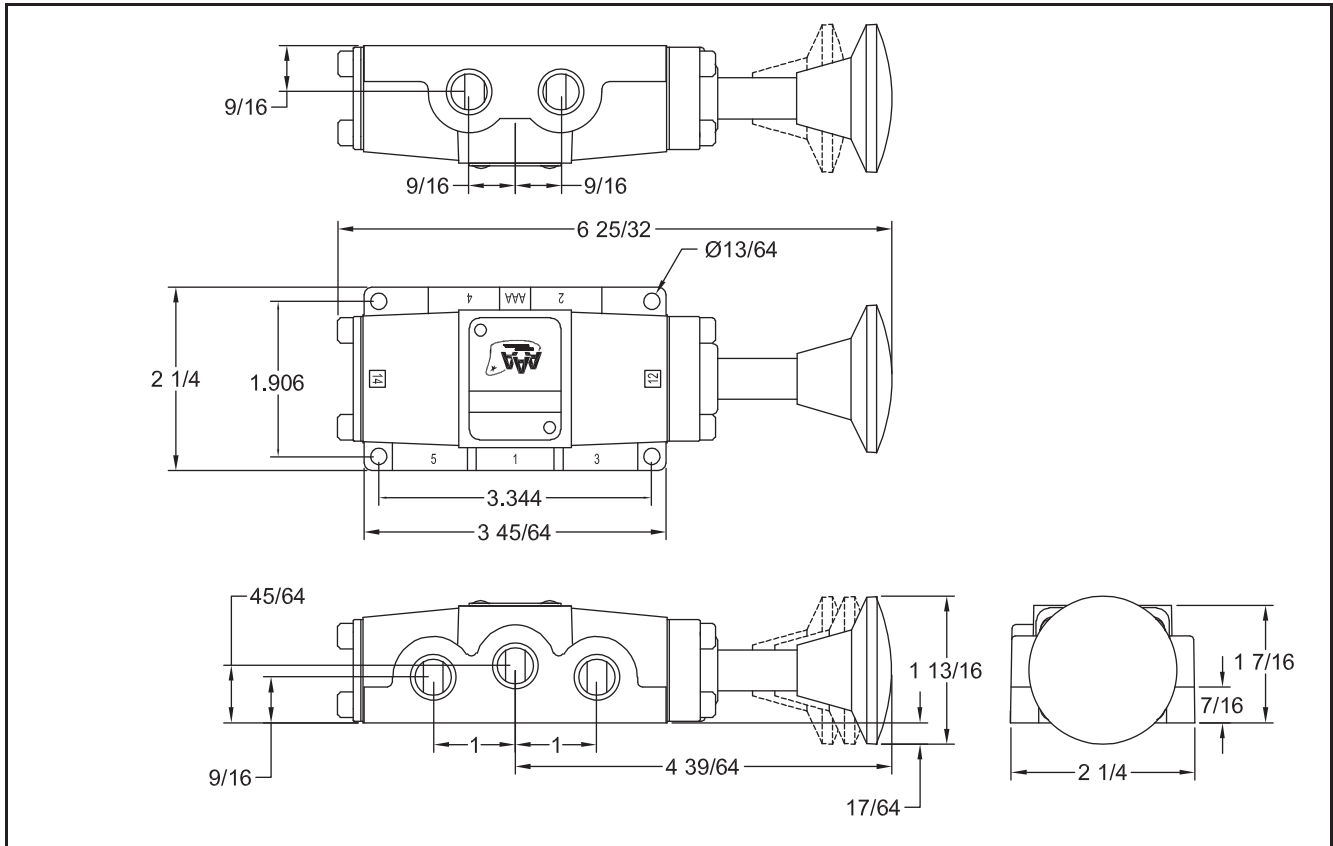

**MODELS: KE3P, KO3P & KD3P**

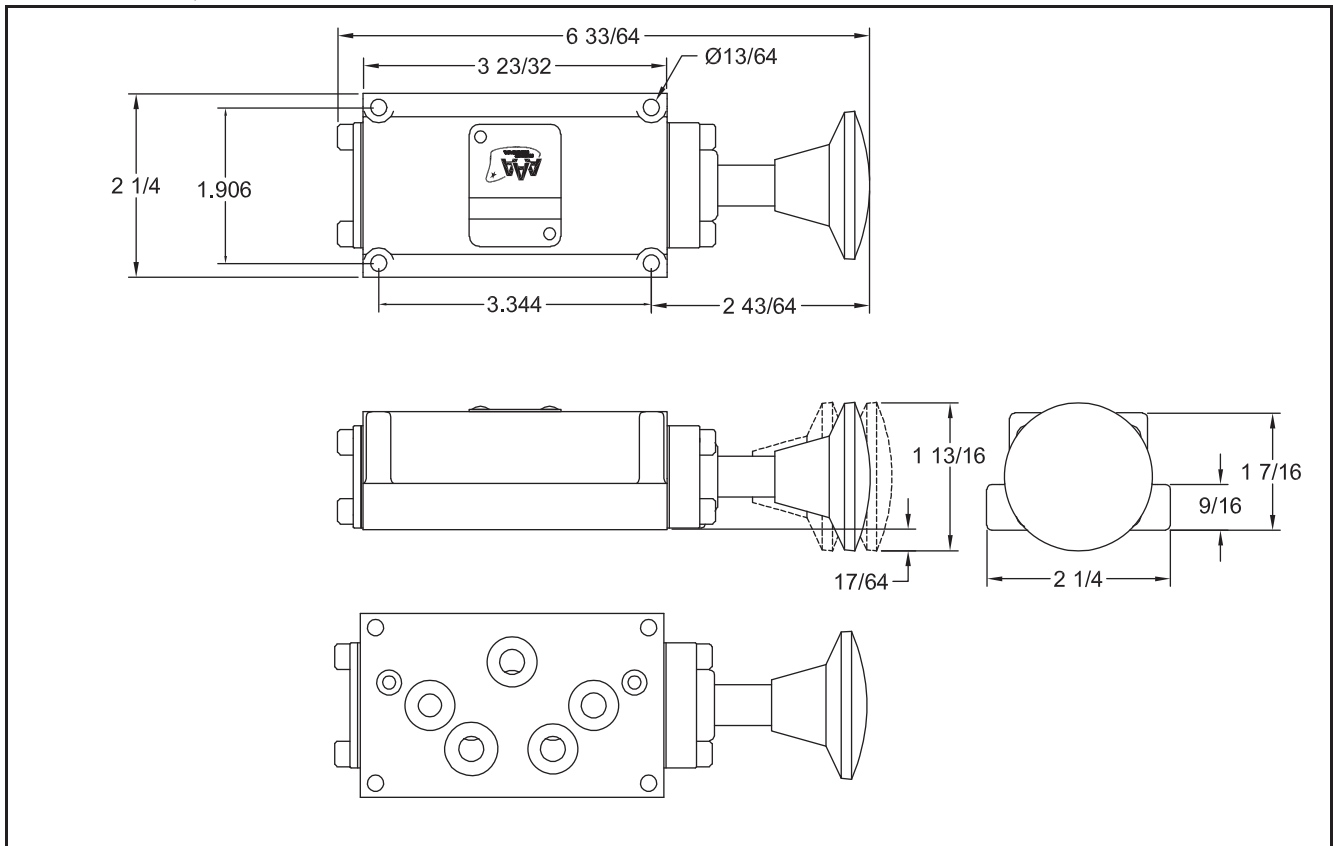

MODELS: KR2, KY2, KR3 & KY3

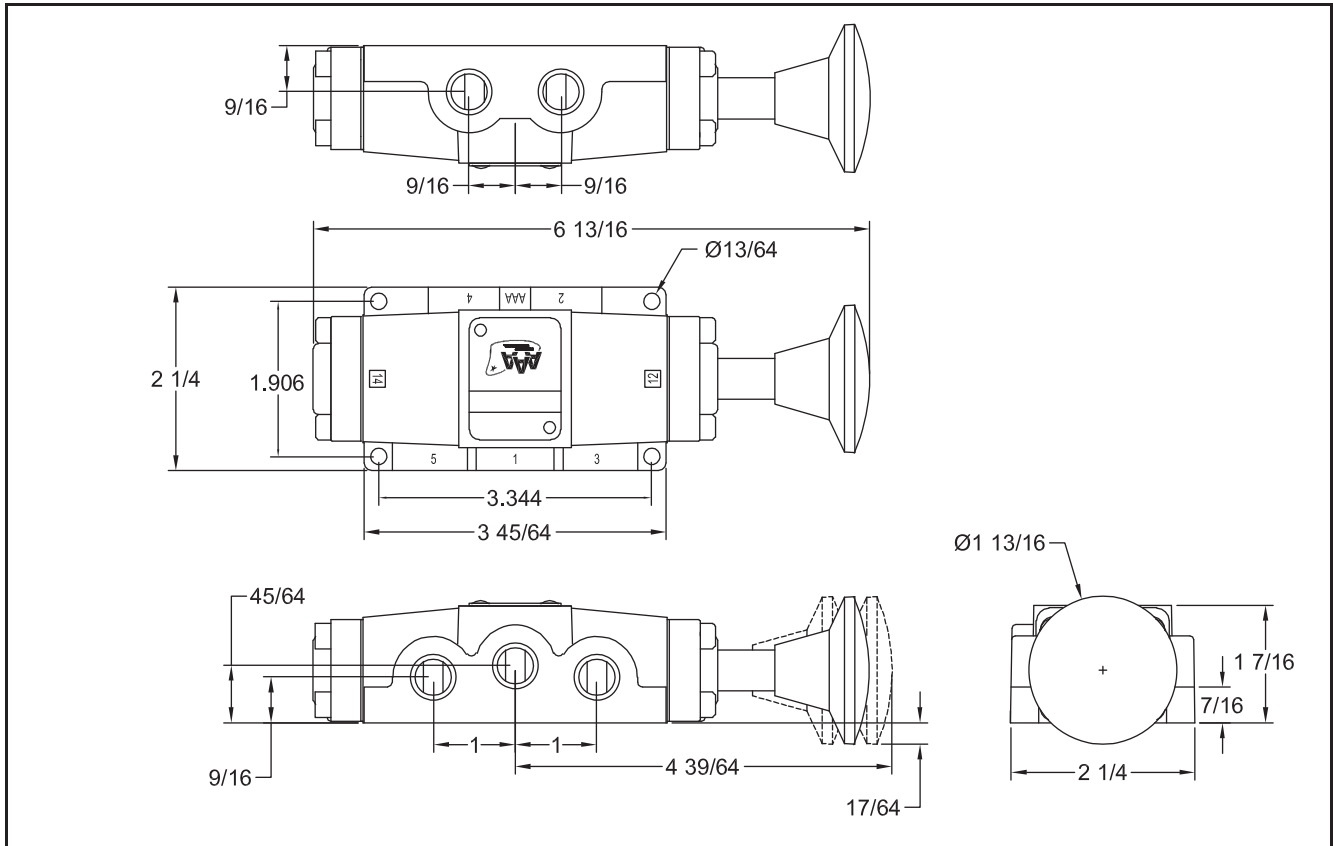

MODELS: KR3P & KY3P

