

PISTON CONTROLLED AIR VALVES

4-WAY: VACUUM TO 250 PSI

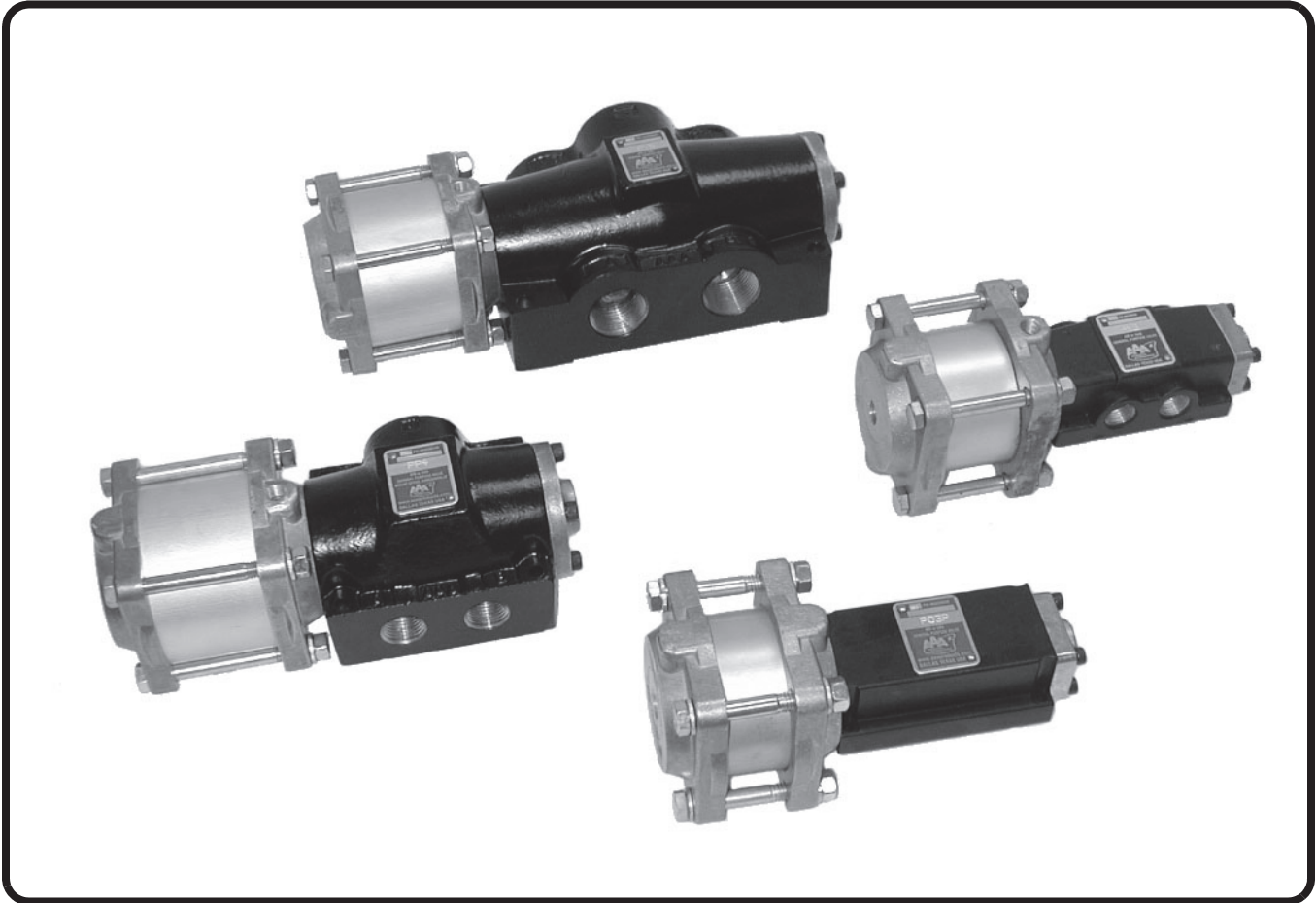

PART NUMBER STRUCTURE:

- Part 1:** The basic part number of an AAA valve is fairly simple to understand. The first part is both an operator style and valve operation. This position describes not only how the valve shifts positions but also what shifts the spool.
- Part 2:** The second portion is the valve port size and body style. This portion describes whether the valve is a threaded side ported body or a bottom bored subplate body.
- Part 3:** The third part of the part number structure is the spool configuration. Normally only needed on three position valves, the spool configuration defines the flow at center position. You can have a spool other than the standard "Closed Center" on two position valves; however, the transitional flow is normally not needed for most applications.
- Part 4:** The fourth position of the part number structure is used to specify valve options.
- Part 5:** The final position allows you to specify different O-rings used in the main valve body. You choose the O-ring most suited for your application. This specification applies to the body O-rings only.

PP3PG -5

1 Operator Style			2 Body Style	
Code	Description	Symbol	Side Ported	Subplate Mounted
PP	2-position, friction positioned. Double acting piston actuator on one end. Spool stays in shifted position when pilot pressure is removed.		2 = 1/4" NPTF 3 = 3/8" NPTF 4 = 1/2" NPTF 6 = 3/4" NPTF 8 = 1" NPTF	
PO	2-position, spring returned spool. Spool returns to position "C" when pilot pressure is removed.			
PY	3-position, spring centered. Double acting piston actuator on one end. Spool returns to center position when pilot pressure is removed.			*3P = 3/8" flow *4P = 1/2" flow 8P = 1" flow

3 Spool Configuration (Normally on 3-position valves, 2-position valves use a closed center spool)

blank = Closed center, all ports are blocked in the center position.
 D = Regenerative center, ports 2 & 4 are connectect to port 1, ports 3 & 5 are blocked.
 G = Float center, port 2 is connected to port 3, port 4 is connected to port 5, port 1 is blocked.

4 Valve Options

blank = No options selected.
 U = Factory installed muffler/flow controls in ports 3 and 5 (body styles 2, 3 & 4 only).

5 Valve O-Ring Option (Only applies to valve body O-Rings)

blank = Viton for body styles 2, 3 & 3P, Buna-N for body styles 4, 6, 8, 12, 4P, 8P & 16P.
 -1 = Neoprene for freon (-40°F to 225°F).
 -2 = Silicon (-80°F to 400°F).
 -3 = Viton for most aromatic gases (-20°F to 400°F, 600°F for short time).
 -4 = Butyl Rubber (-60°F to 200°F).
 -5 = Teflon (-250°F to 450°F).
 -7 = Urethane, 70 Durometer (-65°F to 200°F).
 -9 = Buna-N (-40°F to 250°F).

*Requires custom subplate and recommended only for replacement in existing applications.

GENERAL INFORMATION

Piston models are operated with a larger piston that shifts the spool. This allows you to use lower pilot pressures to shift the valve. Because of the large piston area on the actuator, pilot pressure must be limited to 150 PSI on all models. On body styles 3P and 4P, the piston is larger than the valve, therefore these models require custom subplates and recommended only for replacement in existing applications.

OPERATOR STYLE CODE:

- PO:** 2-position, spring returned spool. Spool returns to position “C” when piston port is exhausted. Shifting pressure should be 12 PSI or greater.
- PP:** 2-position, no springs. Spool shifts and remains shifted when one piston port or the other is momentarily or continuously pressurized. Shifting pressure should be 7 PSI or greater.
- PY:** 3-position, spring centered. Spool returns to position “B” when both piston ports are exhausted or pressurized. Shifting pressure should be 12 PSI or greater.

BODY STYLE:

SIDE PORTED: Side ported valves can be installed inline. These valves have standard female “National Pipe Threads” to connect directly to installed air lines. The standard pipe sizes are 1/4", 3/8", 1/2", 3/4" and 1" NPTF.

SUBPLATE MOUNTED: Subplated valves require a mounting base. This mounting base is pre-plumbed to existing control lines. Due to the nature of all the plumbing lines fixed to a mounting base, replacing subplate mounted valves is rapid and quick. All port connections, excluding piston pilot ports, are made through O-ring sealed holes in the base of the valve through a subplate. O-ring seals and mounting screws are furnished with each subplate valve. Because the connections to a base mount can be of any size and configuration, subplate mounted valves are assigned a designation derived from a basic valve body size. A 3P size subplate valve will have the same flow characteristics as a 3/8" NPTF side ported valve body. Piston control ports can **NOT** be routed through the subplate. On body styles 3P and 4P, the piston is larger than the valve, therefore these models require custom subplates and recommended only for replacement in existing applications.

SPOOL CONFIGURATION (FOR 3-POSITION VALVES):

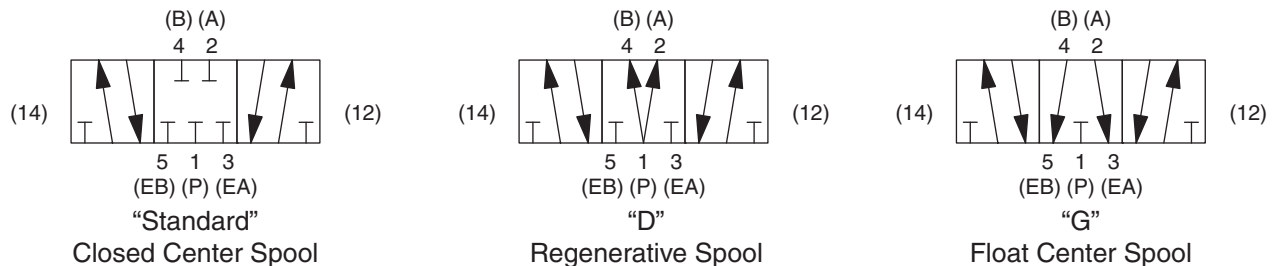

STANDARD: Most valves are supplied with a “Closed Center” spool. In the center position, all ports are blocked. If a valve is only a 2-position valve, the actual function of the center position is not critical. So most 2-position valves are “Closed Center”. Some designs do require softer transitions, so we offer alternate spool configurations on 2-position valves.

REGENERATIVE: Spool Option “D”. In the center position or during transition, ports 2 and 4 are connected to port 1. We call this a “Regenerative” spool since both cylinder ports 2 and 4 are supplied with pressure and flow from port 1.

FLOAT CENTER: Spool Option “G”. In the center position or during transition, port 2 is connected to port 3 and port 4 is connected to port 5. We call this a “Float Center” spool since both standard cylinder ports 2 and 4 are vented to an exhaust port and no pressure or flow from port 1 is supplied.

VALVE OPTIONS:

OPTION U: EXHAUST FLOW CONTROLS

Available only on body styles 2, 3 and 4. A Model MFC flow control, listed on page 146, is screwed into each exhaust port, giving meter-out speed control of an associated air cylinder or air motor in both directions of travel. MFC flow controls not only give adjustable speed control but have a built-in muffler to reduce exhaust noise.

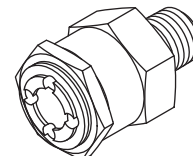

MFC Flow Control

OPTIONAL O-RING MATERIALS:

Unless otherwise specified, all 1/4" and 3/8" soft seal valves come standard with Viton O-rings and all 1/2", 3/4", 1", 1-1/2" and 2" soft seal valves come standard with Buna-N O-rings. If a different material is required, use the dash numbers following the basic valve numbering code. As an example, model SY3G-2 will have Silicon O-rings installed for a low temperature application. On valves larger than 1", consult factory on availability of O-ring materials.

Dash No.	O-ring Description	Temperature Rating
-1	Neoprene for freon	-40°F to 225°F
-2	Silicon	-80°F to 400°F
-3	Viton for most aromatic gases	-20°F to 400°F, 600°F for short time
-4	Butyl Rubber	-60°F to 200°F
-5	Teflon	-250°F to 450°F
-7	Urethane, 70 Durometer	-65°F to 200°F
-9	Buna-N	-40°F to 250°F

We are constantly researching O-ring materials to evaluate performance and durability in the AAA valve product line. Above is a compilation of the most commonly requested O-ring materials and the associated dash number. If you have a particular application that requires an O-ring material that is not listed, please contact us. Since we utilize standard O-ring dimensions in our valves, we can respond to the most obscure O-ring material request.

Note: The piston U-cup material is Buna-N. Piston operators must be piloted with compatible air.

STANDARD TEMPERATURE RANGE:

Operating temperature is dependent upon the seal materials used. The following are temperatures for standard valves:

1/4" and 3/8" valves use Viton O-rings: -20°F to 400°F, 600°F for short time.

1/2", 3/4" and 1" valves use Buna-N O-rings: -40°F to 250°F.

Caution: If it is possible that the ambient temperature may fall below freezing, the medium must be moisture free to prevent internal damage or unpredictable behavior.

FLOW PATTERN:

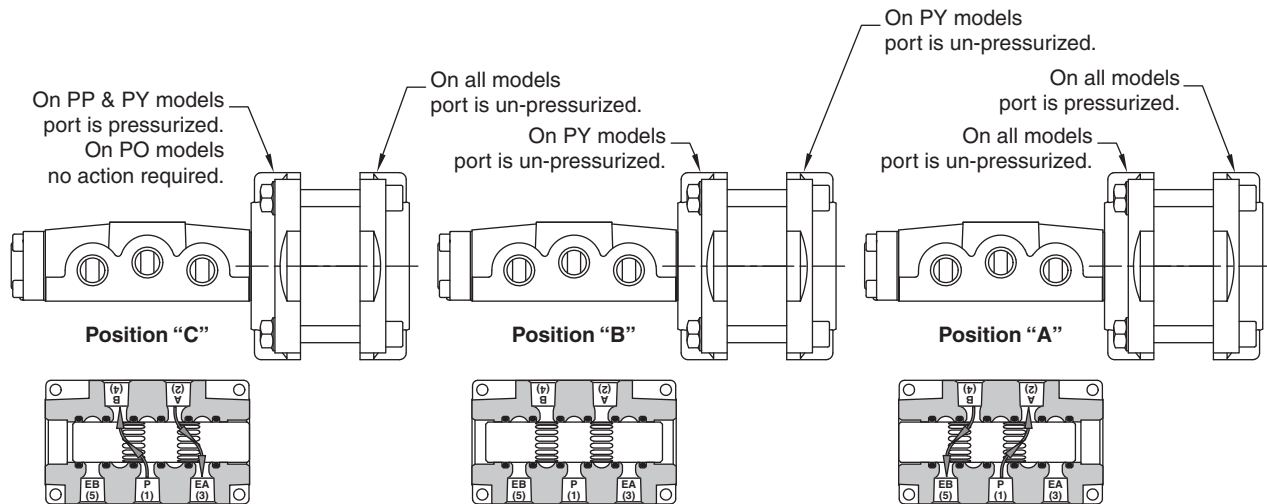

1/4" through 1": When the piston is shifted, causing the internal spool to shift, various ports will be connected. If the piston is in position "A", port 1 will connect to port 2. When the piston is in position "C", port 1 will connect to port 4. The appropriate exhaust will connect to the un-pressurized port. In position "B", the connection of the ports depend on the style of spool used.

AIR FLOW RATINGS:

Test for the determination of flow-rate characteristics conforms to ISO 6358, *Pneumatic fluid power - Components using compressible fluids - Determinations of flow-rate characteristics*. These tests were conducted on AAA valves at the Fluid Power Institute Testing Laboratories of the Milwaukee School of Engineering.

RATED FLOW. Flow factor tests were made with the valve outlet vented to atmosphere and flow in the sonic region. The average flow factor was calculated from tests over a range of inlet pressures. The factor was then used to calculate expected flow at 100 PSIG. Cv values were calculated by graphing the flow (scfm) versus the square root of change in pressure across the valve. A line was fitted to this graph and the resulting slope is the Cv value. Cv uses the theoretical flow (scfm) through the valve when the differential pressure between the inlet and outlet is equal to 1 psi. **We have never lost an application based on either flow or durability.**

Body Style	Rated Flow				
	2	3	4	6*	8*
Port Size	1/4"	3/8"	1/2"	3/4"	1"
SCFM Flow	73.9	97.1	215.0	446.9	477.7
Cv Factor	1.6	2.4	5.0	10.4	11.1

*Tested before the published ISO standards. Cv's were calculated using previous data.

SCFM flow in the above table was calculated for 70 PSIG then converted to 100 PSIG (114.7 PSIA) inlet pressure. At other inlet pressures, SCFM flow will be in proportion to PSIA inlet pressure.

Example: Size 3P at 80 PSIG (94.7 PSIA) inlet pressure.

Ratio of 94.7 to 114.7 is $94.7 \div 114.7 = 0.826$

Flow at 80 PSIG = $0.826 \times 97.1 = 80.2$ SCFM.

LIMITATIONS ON VACUUM OPERATION

The five main ports on AAA valves can be operated on industrial vacuum to 28" Hg, based on a 30" barometer. O-rings between all ports give tight sealing. While AAA valves are basically 4-way, they can be used for 3-way service by plugging the unused 2 (A) or 4 (B) port.

MOUNTING OF VALVES

AAA valves may generally be mounted in any position. But for safety, any valve which does not have springs or detents to hold the spool in position should be mounted with the spool horizontal unless pressure is continually applied to hold the spool in position.

UNIQUE MOUNTING CONCERN

On body styles 2 and 3, the piston actuator is larger in diameter than the valve body, a 1-1/4" spacer should be used when mounting on a flat surface. On body styles 3P and 4P, the piston is larger than the valve, therefore these models require custom subplates and recommended only for replacement in existing applications.

SEAL KITS:

ERKV-3: One kit required for each 1/4" or 3/8" valve. Includes six V-39 Viton body O-rings, two EMG3 Buna-N solenoid gaskets, two ECG3 composition end cap gaskets, two V-565 Buna-N Namur mounting O-rings, one PBG3 gasket, one PBG3-1 gasket, five V-92 Buna-N subplate O-rings and two V-93 Buna-N subplate pilot O-rings (Seals used determined by valve model and style).

ERKV-4: One kit required for each 1/2" valve. Includes six V-6 Buna-N body O-rings, two EMG3 Buna-N solenoid gaskets, two ECG48 composition end cap gaskets, five V-110 Buna-N subplate O-rings, two V-29 Buna-N subplate pilot hole O-rings (Seals used determined by valve model and style).

ERKV-8: One kit required for each 3/4" or 1" valve. Includes six V-30 Buna-N body O-rings, two EMG3 Buna-N solenoid gaskets, two ECG48 composition end cap gaskets, five V-90 Buna-N subplate O-rings, two V-89 Buna-N subplate pilot hole O-rings (Seals used determined by valve model and style).

RKPV-3A: One kit required for each 1/4" or 3/8" valve to replace all the seals in the piston. Each kit includes one V-89 Buna-N O-ring, two V-115 Buna-N U-cups (Only one used on PO models) and two V-165 composition barrel gaskets (Does not include any valve body seals).

RKPV-48A: One kit required for each 1/2", 3/4" or 1" valve to replace all the seals in the piston. Each kit includes one V-89 Buna-N O-ring, two V-102 Buna-N U-cups (Only one used on PO models) and two V-166 composition barrel gaskets (Does not include any valve body seals).

VGK-3: AAA valve grease to lubricate body O-rings during valve overhaul (Each seal repair kit does supply enough grease for complete seal replacement).

SEMI-DIMENSIONAL DRAWINGS:

MODELS: PP2 & PP3

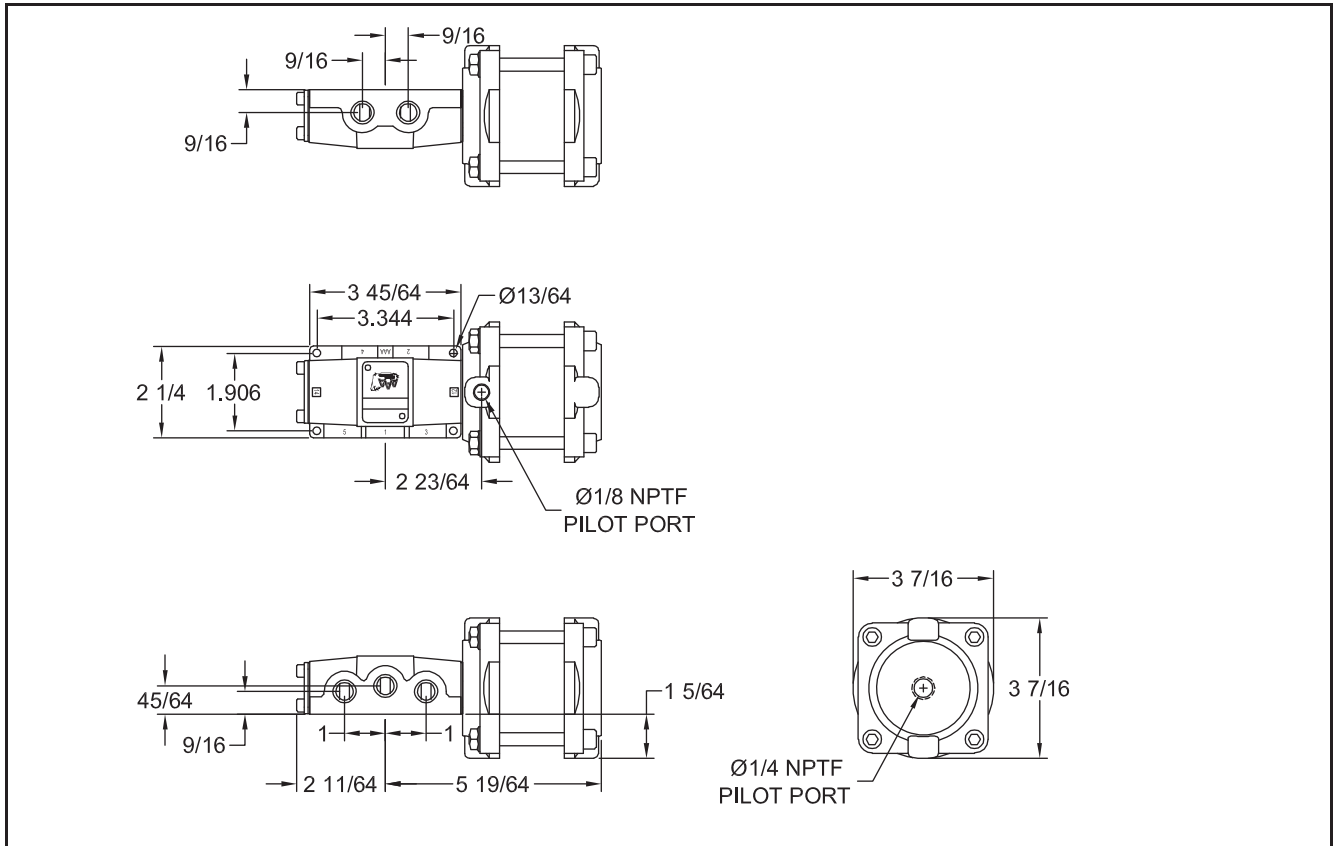

MODELS: PY2 & PY3

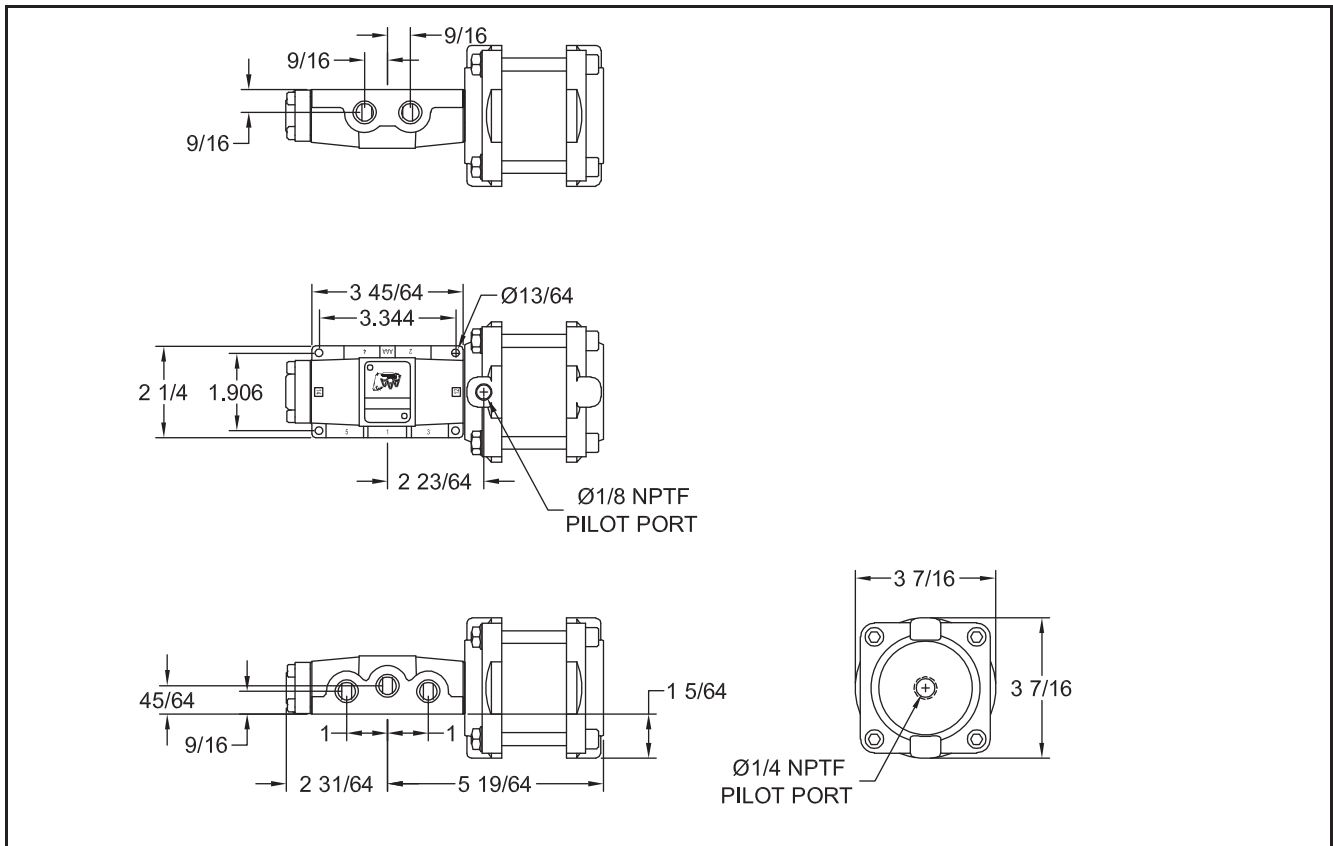

STANDARD 1/4" THROUGH 2"
PISTON: PP, PO, PY

MODELS: PO2 & PO3

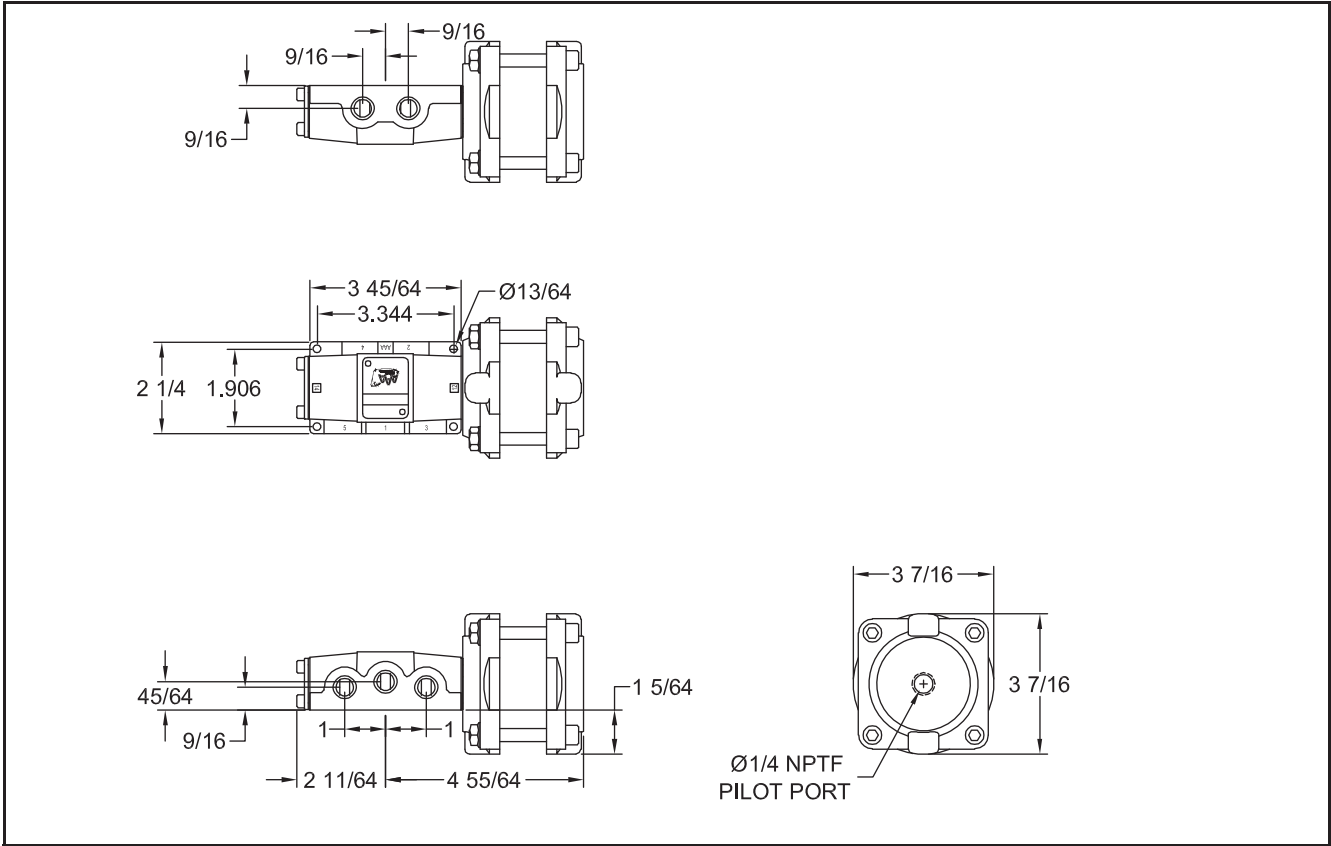

MODELS: PP3P

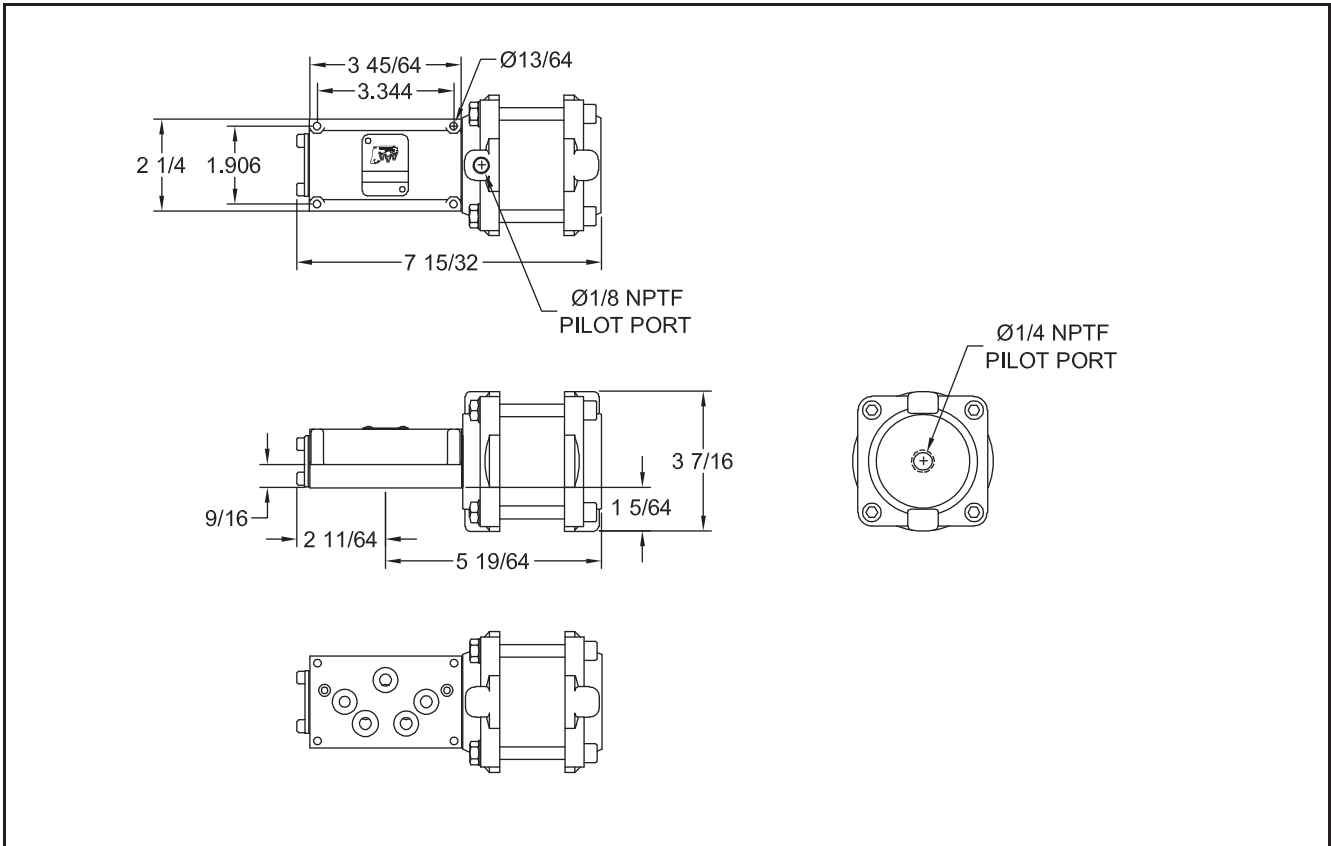

MODELS: PY3P

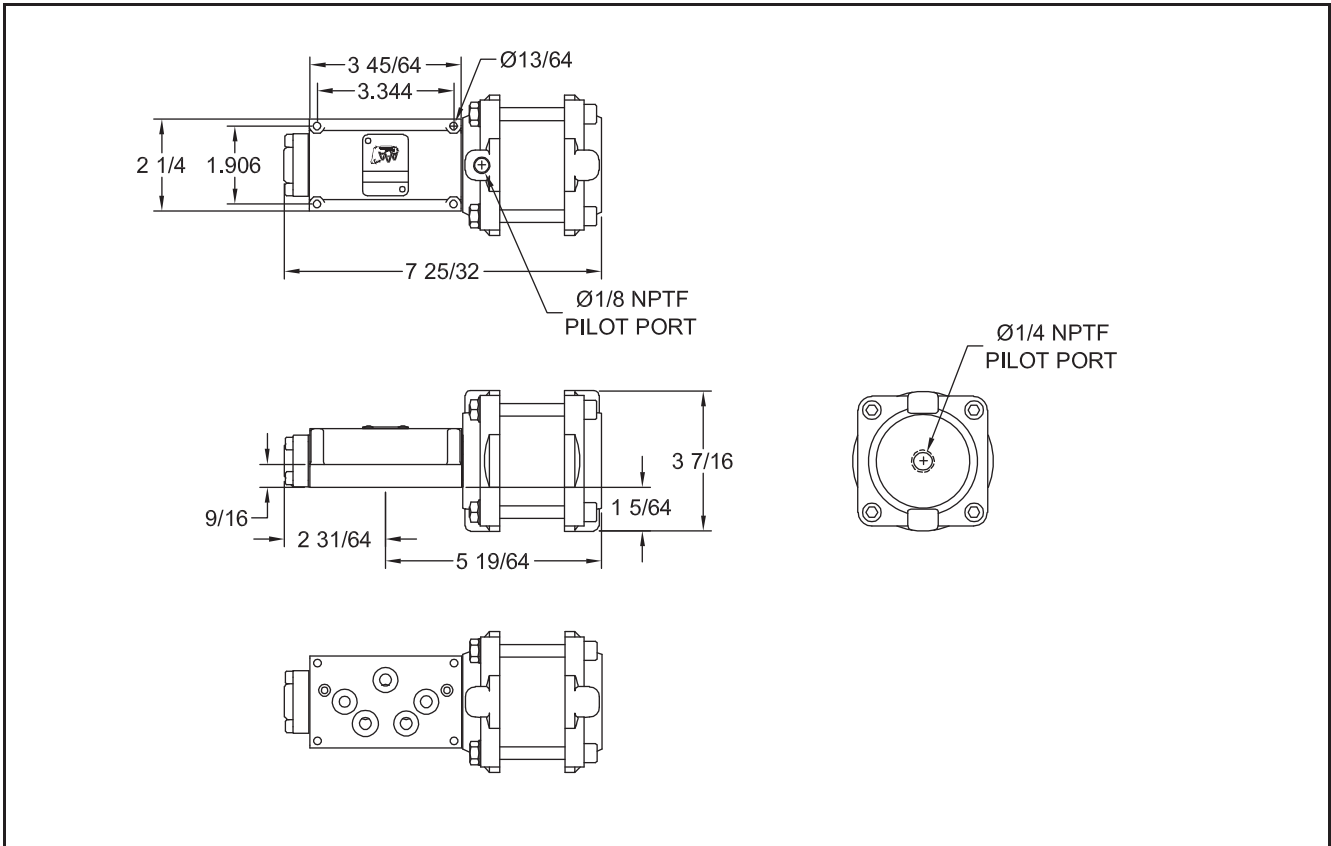

MODELS: PO3P

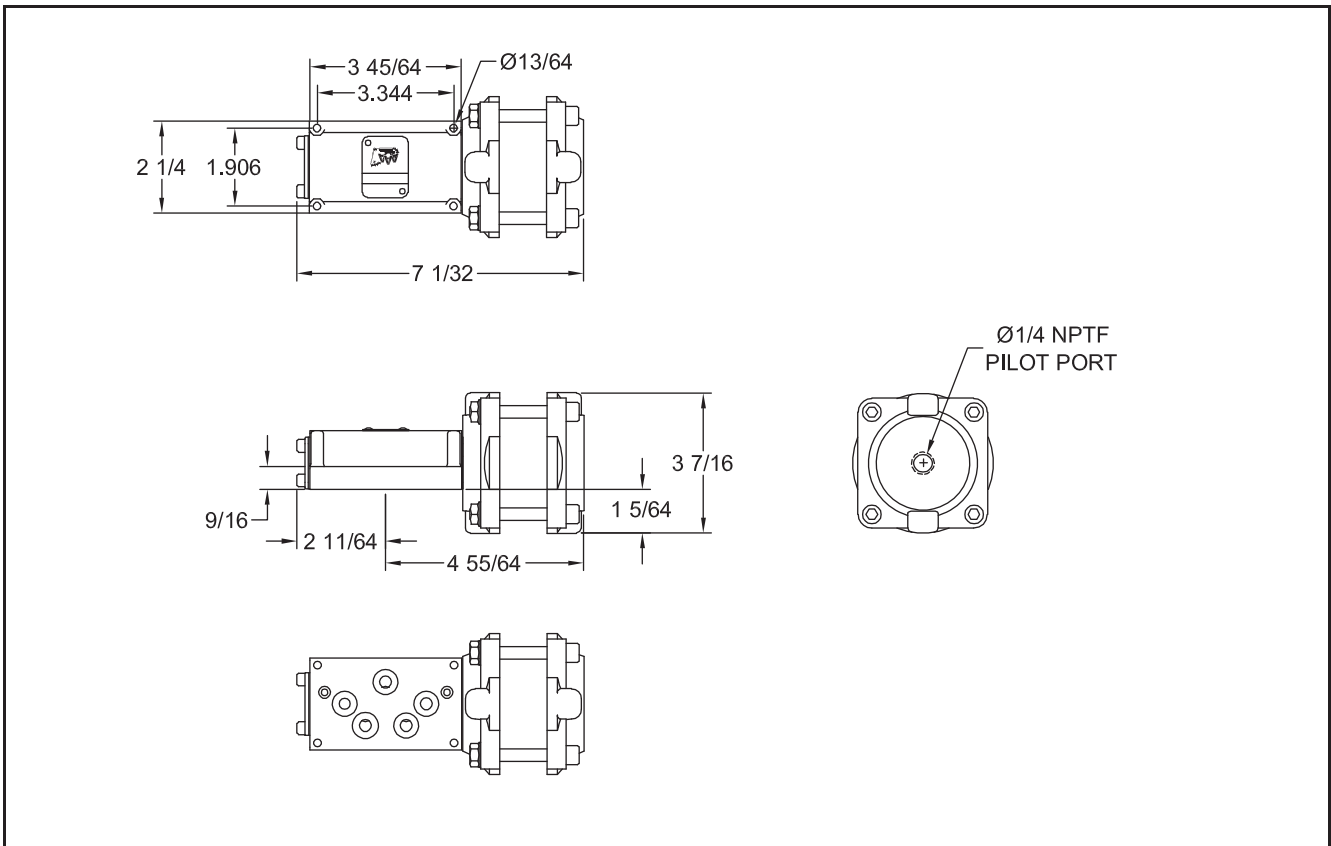

STANDARD 1/4" THROUGH 2"
PISTON: PP, PO, PY

MODELS: PO4 & PO4P

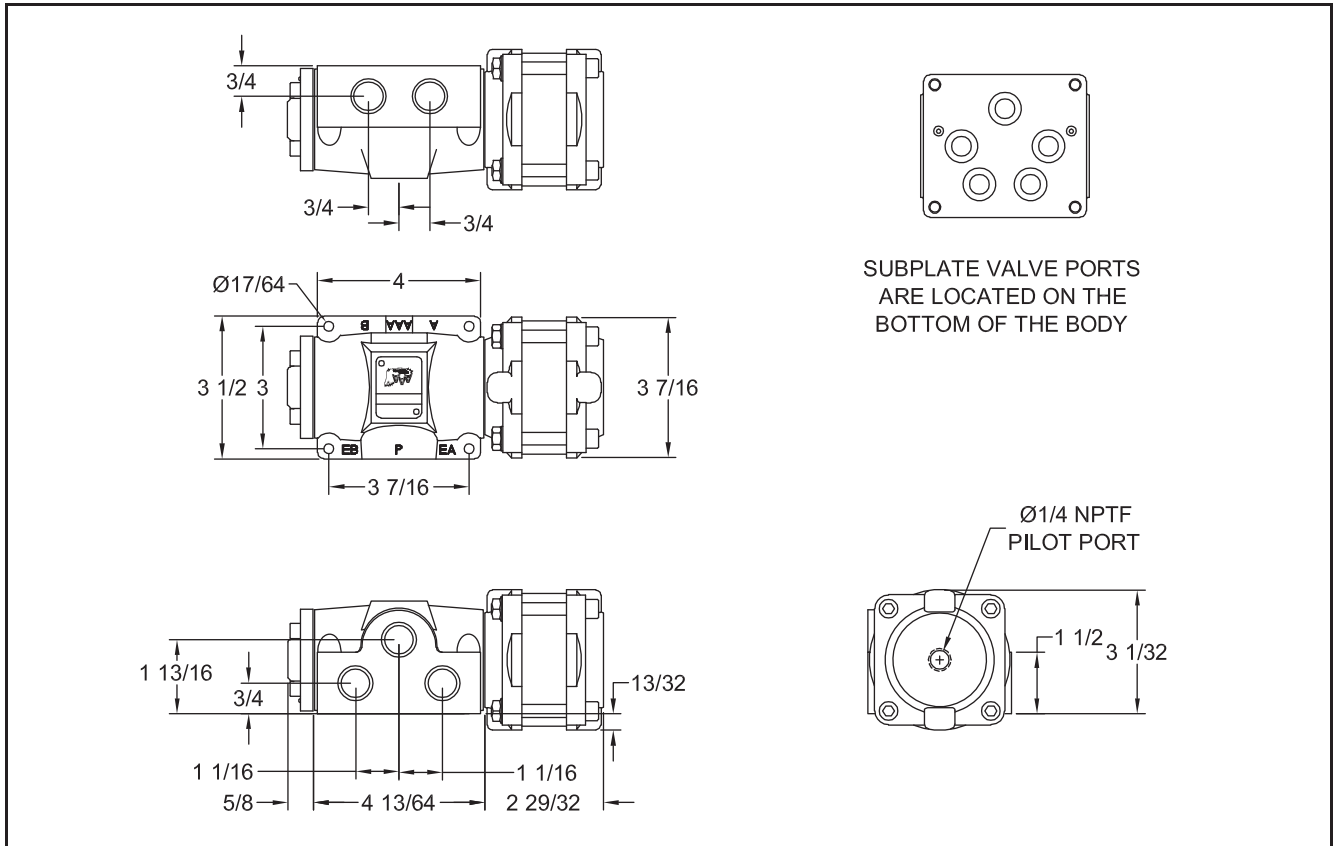

MODELS: PP4, PY4, PP4P & PY4P

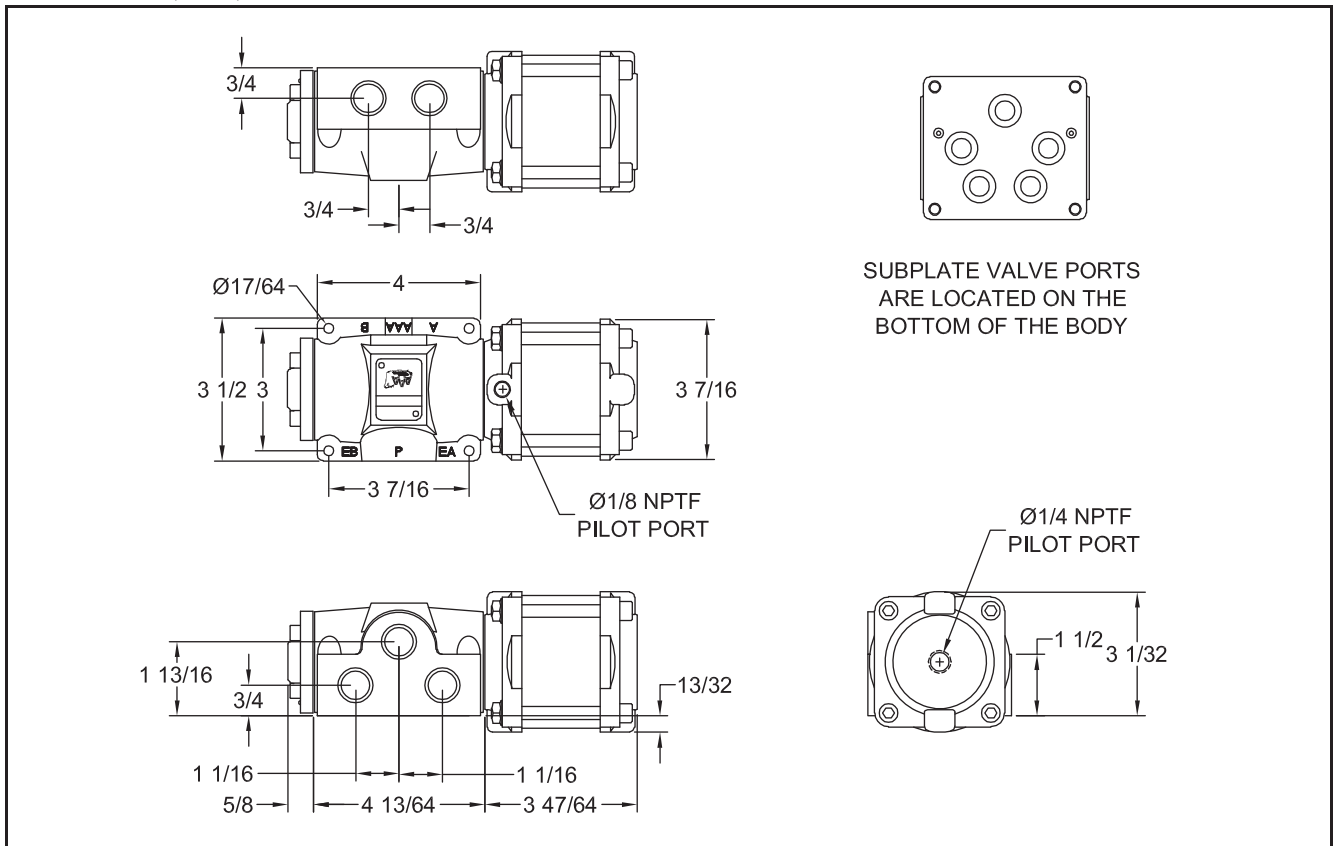

MODELS: PO6, PO8 & PO8P

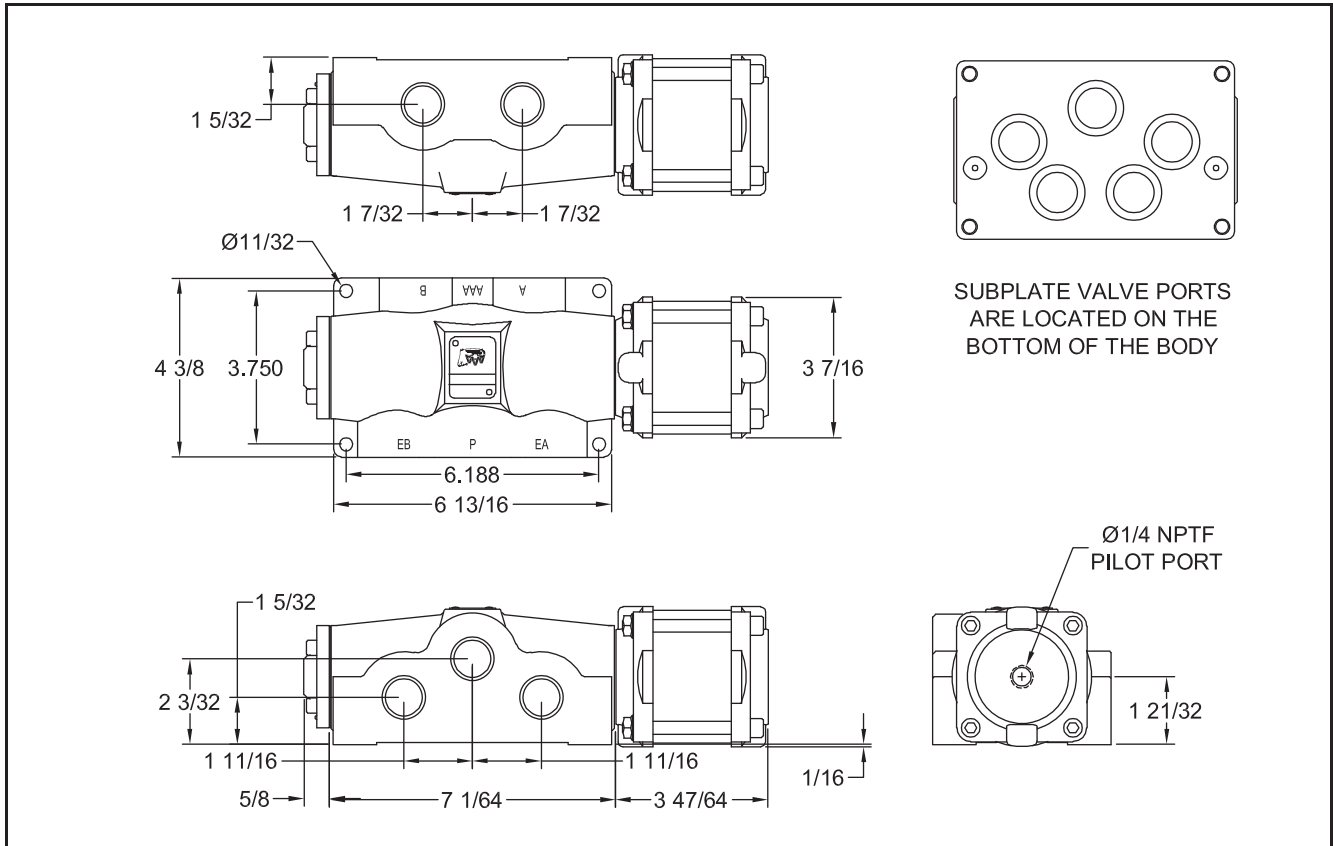

MODELS: PP6, PY6, PP8, PY8, PP8P & PY8P

